

SMART LIVING





One Touch Cleaning



Dismantable Front Ducting Panel For Easy Cleaning



SMART SENSOR

Just WAVE to POWER ON /OFF and changing SPEEDS

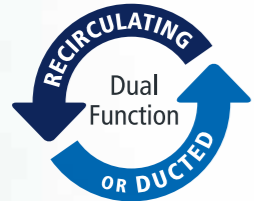

The future of kitchen innovation is now here! Morgan's Powerful Revolution Smart Series Hood with GESTURE CONTROL & AUTO HEAT CLEANING redefines the way you cook, and clean-up after cooking. No more oily or wet hands touching function buttons. Just a convenient wave of the hand will do!



Heating Device Heats Up Oil



Oil Softens and is Dissolved



Oil Residues Flow Into Oil Cup

AUTO HEAT CLEANING

Morgan's innovative Auto Heat Cleaning Technology uses centrifugal force to heat up and dissolve oil residues in the air chamber and metal exhaust fan. Your kitchen hood stays clean for optimal performance.

TO DUCT OR RECIRCULATE?

In the kitchen, it is ideal to use a ducted hood that vents outdoors to ensure optimal air extraction. However, this may not always be practical.

In contrast, the majority of Morgan range hoods are equipped with a recirculation made that passes air through a metal filter to remove grease, and then through a carbon filter returning the purified air to the kitchen.

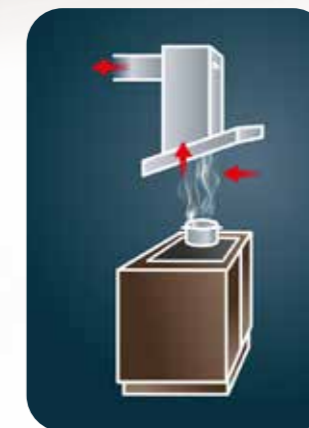

Ducted Ventilation

- Extracts odours up to 98%
- Extracts steam
- Requires ducting system

** It is recommended to leave a window ajar when operating the ducting system.*

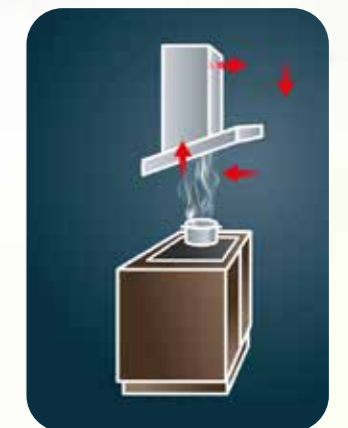

Recirculated Ventilation

- Clean air filter eliminates cooking odours
- Easy installation – requires no ducting
- Requires separate recirculation kit



- **Blue Concentrated Flame**
For maximum heating power and better combustion
- **Multi-directional Air Supply**
For stable, consistent combustion
- **Extended Ejector Tube**
Fully mixes air & gas with strong gas suction



Powerful Flame with Heat Deflector



Duplicast Iron Trivets



Energy concentrator for stronger flame



Safety Valve

The Morgan OPTIFLEX series ensure powerful, heat-concentrated flames with stable combustion and it elevate your cooking with enhanced flavours and cooking results.

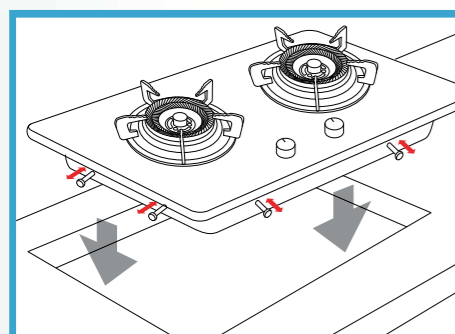

FITS EASILY INTO YOUR EXISTING COOKTOP SPACE

Recommended fitting dimensions (mm):

- MBH-622 OPTIFLEX:
635-735(W) x 350-421(D)
- MBH-SD625 OPTIFLEX:
640-730(W) x 360-410(D)
- MBH-SD635 OPTIFLEX:
635-820(W) x 350-460(D)

you can easily make use of its adaptable cut-out dimension to replace your old burner and experience the differences.



Burner Cap

Outer Burner

Burner Base

Safety Device



Burner

Sparker

Safety Device

MBH-SD2112

BUILT-IN PACKAGE



Dismantable Front Ducting Panel For Easy Cleaning



Motion Control



One Touch Cleaning



Vent Cap



Heat Auto Cleaning



Metal Blower

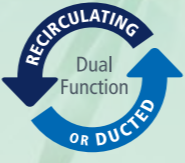

Dual Function



DESIGNER HOOD MDH-997MHC

- 1800m³/hr extraction capacity
- 3 Speed motor with Sensor Touch control
- Motion control and Touch control
- With Heat Auto-Cleaning Function
- With Metal blower
- LED light
- With rectangle oil cup
- With Charcoal filter
- With 1 minute delay timer function
- Dimension of ducting hole: Ø180mm
- 2 chimneys
- 3 meters double layer aluminium foil ducting hose
- With wall vents cap Ø180mm
- 2 years warranty on motor

RM1579(WM) RM1729(EM)
RRP: RM1668(WM) RM1818(EM)

BUILT-IN PACKAGE



Metal Blower



Oil Collector



LED Light



DESIGNER HOOD MDH-926MHC

- Black Coated Stainless Steel & Tempered Glass Finishing
- Suction Power: Up to 1400m³/hr
- Control Panel: 3 Speed Touch Control & Touchless Smart Motion Sensor
- With Heat Auto-Cleaning Function
- Washable baffle filter
- LED light
- With rectangle oil cup
- With Charcoal filter
- 2 Chimneys
- With Metal blower
- Duct out or Recirculation system

RM1019(WM) RM1119(EM)
RRP: RM1158(WM) RM1258(EM)



RANGE HOOD MCH-ND390(BK)

- 900mm Slim Hood
- Wall Mount
- Twin motors with suction power up to 900m³/h
- 3-Ply aluminum filters for efficient removal of cooking grease
- Charcoal filters for removal of odors
- Duct Out or Recirculating System
- Push Button
- 3 Speed Selection
- 2 X LED light
- Washable Filter
- Copper Motor
- Full black chassis with black front panel

RM739(WM) RM789(EM)
RRP: RM908(WM) RM958(EM)

OR

UPGRADE From MBH-GC522C (BK)



BUILT-IN HOB MBH-166SS

- Stainless steel top
- Powerful flame: L/R: 4.25kW
- 2 Burner stainless steel hob
- With safety valve
- Battery ignition
- Easy to clean surface

RRP: RM439(WM) RM459(EM)

BUILT-IN HOB MBH-622 OPTIFLEX

- Tempered glass 8mm
- Powerful flame – L/R: 4.3kW
- Flexible to fit in any cut out size
- Duplicast iron trivets

RRP: RM629(WM) RM649(EM)

BUILT-IN HOB MBH-SD635 OPTIFLEX

- Tempered glass 8mm
- Powerful flame – L/R: 5.0kW
- Duplicast iron trivets
- With heat deflector
- With energy concentrator
- With safety valve
- Flexible to fit in any cut out size

RRP: RM779(WM) RM809(EM)



ADD ON: **RM20(WM) RM20(EM)**



ADD ON: **RM210(WM) RM210(EM)**



ADD ON: **RM360(WM) RM370(EM)**



BUILT-IN HOB MBH-GC522C(BK)

- Tempered glass 8mm
- Powerful flame – L/R: 4.0kW
- Enamel coated trivets

RRP: RM419(WM) RM439(EM)



BUILT-IN HOB MBH-SD2112

- Tempered glass 8mm
- Powerful flame – L/R: 4.5kW
- Duplicast iron trivets
- 2 Burner caps (mm): 125 x 125
- Battery Ignition
- Easy to maintain and clean surface
- With Safety device

RRP: RM439(WM) RM459(EM)



ADD ON: **RM20(WM) RM20(EM)**

PWP

with purchase of any MORGAN Hob Hood package will entitle to buy:



Ceramic Cooker (MCC-2002) at **RM149(WM) / RM159(EM)**



Pan Grill (MPG-DA898NS) at **RM189(WM) / RM199(EM)**

OR

HOB/HOOD SPECIFICATION

AIR FRYER

* MBH-SD635 OPTIFLEX



Duplicast Iron Trivets



Safety Valve

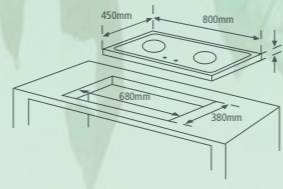

MBH-GC522C(BK) ROBUSTO

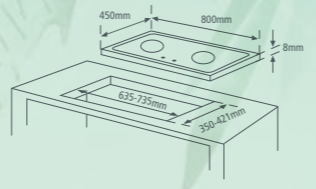

MBH-622 OPTIFLEX

MBH-622 OPTIFLEX



Powerful Flame



Duplicast Iron Trivets

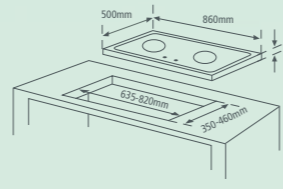

MBH-SD635 OPTIFLEX

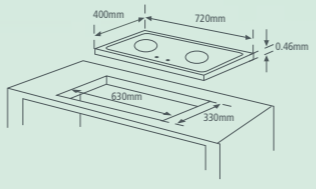

MBH-1665S

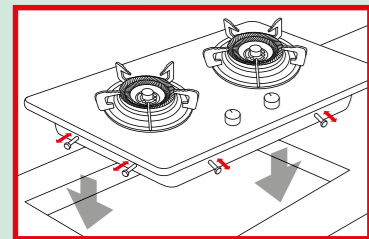

FITS EASILY INTO YOUR EXISTING COOKTOP SPACE

Recommended fitting dimensions (mm):

- MBH-622 OPTIFLEX: 635-735(W) x 350-421(D)
- MBH-SD635 OPTIFLEX: 640-730(W) x 360-410(D)
- MBH-SD635 OPTIFLEX: 635-820(W) x 350-460(D)

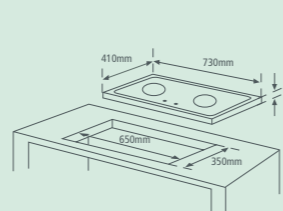

MBH-GC1122 ENDURE / MBH-SD2112

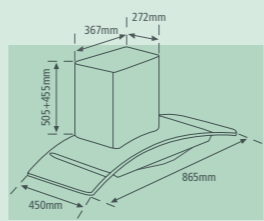

MDH-926MHC

MBH-GC522C(BK) ROBUSTO



Powerful Flame



Enamel Coated Trivets

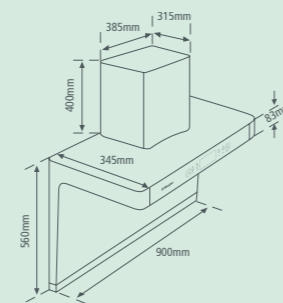

MDH-997MHC

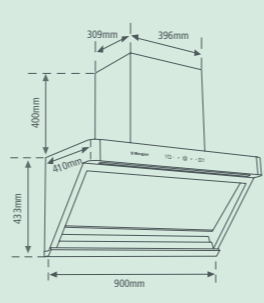

MDH-996MHC

MBH-SD2112



Powerful Flame



Duplicast Iron Trivets/ Safety Valve

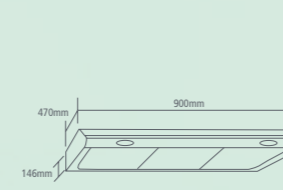

MCH-ND390(BK)

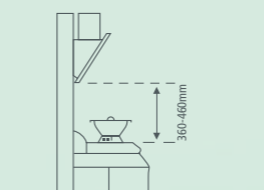

SLANTED HOOD

MBH-1665S



Powerful Flame



Duplicast Iron Trivets

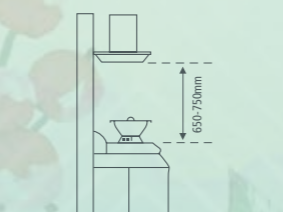

T-HOOD/ARCH-GLASS HOOD

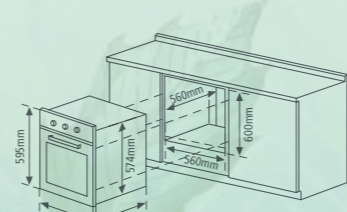

MBO-7680D



AIR-FRYER MAF-OPTIMAL 8

- Power: 1200W
- Capacity: 8.0L
- Removable inner pot with non-stick coating
- With rapid air circulation system
- Temperature control 80°C to 210°C
- With timer up to 99 minutes

RM309(WM) RM329(EM)
RRP: RM339(WM) RM359(EM)



Ideal for Roasting



Frying without Oil



Ideal For Grilling



Ideal for Baking



3D Rotation Cooking



LED Display Panel



Accessories



Removable Inner Pot Design



AIR FRYER MAF-C707

- Power: 1800W
- Capacity: 7.7L
- Temperature control 80°C-200°C
- With timer up to 30 minutes
- Ideal for Roasting, Grilling and Frying without oil
- With non-stick coating pot
- Extra large capacity for various cooking needs
- With rapid air circulation system

RM219(WM) RM239(EM)
RRP: RM239(WM) RM259(EM)



Frying without Oil



Ideal for Roasting



Ideal For Grilling

MBH-SD2112



Powerful Flame



Duplicast Iron Trivets/ Safety Valve

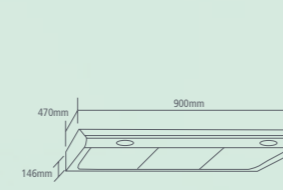

MCH-ND390(BK)

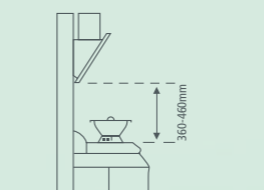

SLANTED HOOD

MBH-1665S



Powerful Flame



Duplicast Iron Trivets

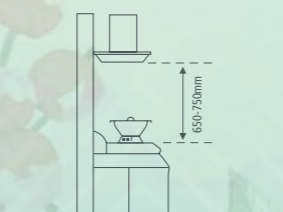

T-HOOD/ARCH-GLASS HOOD

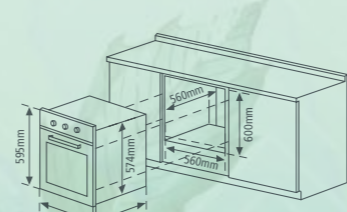

MBO-7680D



Frying without Oil



Ideal for Roasting



Ideal For Grilling



Large LED Digital Display

DIGITAL AIR FRYER MAF-946D

- Power: 1300-1500W
- Capacity: 4.5L
- Adjustable Temperature Setting 80°C-200°C
- Touch screen with 12 presets control panel
- LED digital display
- With timer up to 60 minutes
- FDA Safe Non-stick Coating Frying Pot and easy cleaning
- With Rapid Air Circulation Technology
- With safety cut-off switch when basket is pull out during operation.
- Automatic shut-off

RM219(WM) RM229(EM)
RRP: RM239(WM) RM249(EM)



AIR FRYER MAF-C607

- Power: 1300W
- Capacity: 2.8L
- Temperature control 80° - 200°C
- With timer up to 60 minutes
- Removable pot with non-stick coating
- With rapid air circulation system
- Overheat protection and handle button cover

RM179(WM) RM189(EM)
RCP: RM189(WM) RM199(EM)



Frying without Oil



Ideal for Roasting



Ideal For Grilling

ELECTRIC OVEN



ELECTRIC OVEN MEO-HC26C

- Power: 1500W
- Capacity: 26 Liter
- 6 function selector: OFF, upper heating, lower heating, both upper & lower heating, upper heating with convection and both upper & lower heating with convection
- 100°C-250°C Adjustable Temperature Selector for Various Cooking Functions
- 60min Timer With Bell Ring
- Stainless Steel Heating Element
- With Indicator Light
- Accessories: 1pc Bake Tray, 1pc Wire Rack & Tray Handle

RM179(WM) RM199(EM)
RRP: RM189(WM) RM209(EM)



ELECTRIC OVEN MEO-GLAMO 100RC

- Power: 2800W
- Capacity: 100L
- 8 function selector: OFF, Fermentation, Upper heating, Lower heating, Upper + Lower heating, Upper + Lower heating with Convection, Upper + Lower heating with Rotisserie and Upper + Lower heating with Convection + Rotisserie.
- With defrost function (at top temperature control knob)
- 70°C to 250°C adjustable temperature selector for various cooking functions
- 2pcs "M" shape Stainless steel heating elements
- Independent temperature control. (Top & bottom temperature can be adjusted separately.)
- 120 minutes switch off timer with ring.
- With inner oven lamp
- Accessories: Rotisserie set, wire rack, 2pcs enamel baking tray, crumb tray and tray handle.

RM609(WM) RM679(EM)
RRP: RM669(WM) RM739(EM)



ELECTRIC OVEN MEO-GLAMO 150RCSS

- Power: 2800W
- Capacity: 150L
- 8 function selector: OFF, Fermentation, Upper heating, Lower heating, Upper + Lower heating, Upper + Lower heating with Convection, Upper + Lower heating with Rotisserie and Upper + Lower heating with Convection + Rotisserie.
- With defrost function (at top temperature control knob)
- 70°C to 250°C adjustable temperature selector for various cooking functions
- 2pcs "M" shape Stainless steel heating elements
- Independent temperature control. (Top & bottom temperature can be adjusted separately.)
- 120 minutes switch off timer with ring.
- With inner oven lamp
- Accessories: 3pcs enamel baking tray, rotisserie set, rotisserie Basket, wire rack, crumb tray and tray handle

RM969(WM) RM1069(EM)
RRP: RM1069(WM) RM1169(EM)



RICE COOKER



Convenient Lid Holder



Accessories

COMMERCIAL RICE COOKER MCR-VAST 10

- Power rating: 2800W
- Capacity: 10L
- Large control panel with 1 button easy operation
- Stainless steel large handle lid with holder for hung on the side of the pot
- Removable non-stick inner pot
- With keep warm functions
- With overheat cut-off protection
- Max rice volume: 7.5kgs & min rice volume 2kgs; Max. up to 50 persons

RM349(WM) RM379(EM)
RRP: RM399(WM) RM429(EM)



COMMERCIAL RICE COOKER MCR-VAST 7

- Power rating: 2500W
- Capacity: 6.6L
- Large control panel with 1 button easy operation
- Stainless steel large handle lid with holder for hung on the side of the pot
- Removable inner pot with non-stick coating
- With keep warm functions
- With overheat cut-off protection
- Max rice volume: 5kgs & min rice volume 1.6kgs; Max. up to 35 persons

RM259(WM) RM279(EM)
RRP: RM289(WM) RM309(EM)



Non-stick Coated Inner Pot



Accessories



JAR RICE COOKER MRC-2318J

- Power rating: 700W
- Capacity: 1.8L
- Non-stick coated inner pot
- With detachable steam vent
- With steam tray

RM109(WM) RM119(EM)
RRP: RM129(WM) RM139(EM)



RICE COOKER MRC-TC06NS

- Power rating: 350W
- Capacity: 0.6L
- Glass Lid
- Non-stick Coated Inner Pot
- With Over-heating Protection
- Cook & auto keep warm function
- Accessories: rice scoop and measuring cup

RM69(WM) RM70(EM)
RRP: RM88(WM) RM89(EM)

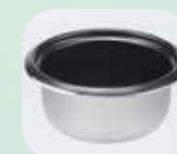

Non-stick Coated Inner Pot



Accessories



RICE COOKER MRC-TD618NS

- Power rating: 700W
- Capacity: 1.8L
- Stainless steel lid
- Non-stick coated inner pot
- Aluminium steaming basket

RM89(WM) RM99(EM)
RRP: RM109(WM) RM119(EM)



RICE COOKER MRC-TD610NS

- Power rating: 400W
- Capacity: 1.0L
- Stainless steel lid
- Non-stick coated inner pot
- Aluminium steaming basket

RM79(WM) RM89(EM)
RRP: RM89(WM) RM99(EM)



RICE COOKER MRC-TC28

- Power rating: 1000W
- Capacity: 2.8L
- Micro switch control
- With steam tray

RM119(WM) RM129(EM)
RRP: RM139(WM) RM149(EM)



RICE COOKER MRC-TC10

- Power rating: 400W
- Capacity: 1.0L
- Micro switch control
- With steam tray

RM79(WM) RM89(EM)
RRP: RM89(WM) RM99(EM)

GAS STOVE



DOUBLE GAS STOVE MGS-8812G

- 115mm x 115mm Cast Iron Burner Head
- Powerful flame – L/R: 3.6kW
- Glass Top For Elegant Look & Easy Cleaning
- Black Coated Iron Base
- Enamel Trivet for Durability

RM179(WM) RM189(EM)
RRP: RM199(WM) RM209(EM)



DOUBLE GAS STOVE MGS-7010

- 100mm + 100mm Beehive Burner Head
- Powerful flame – L/R: 3.2kW
- Elegant Design
- Enamel Trivet for Durability

RM79(WM) RM89(EM)
RRP: RM89(WM) RM99(EM)



DOUBLE GAS STOVE MGS-9613S

- 125mm + 125mm Copper Burner Head
- Powerful flame – L/R: 4.5kW
- 100% Stainless Steel Body
- Elegant Design
- Enamel Trivet for Durability

RM179(WM) RM189(EM)
RRP: RM189(WM) RM199(EM)



DOUBLE GAS STOVE MGS-7212S

- 120mm x 120mm stainless steel burner head
- Powerful flame – L/R: 3.1kW
- Stainless steel top
- Double pipe
- Enamel trivet for durability
- Piezo ignition

RM129(WM) RM139(EM)
RRP: RM139(WM) RM149(EM)



DOUBLE GAS STOVE MGS-7313S

- 130mm x 130mm stainless steel burner head
- Powerful flame – L/R: 3.6kW
- Stainless steel top
- Double pipe
- Double 8 jets burner
- Piezo ignition

RM139(WM) RM149(EM)
RRP: RM149(WM) RM159(EM)



PAN GRILL MPG-DB899NS

- Power rating: 1600W
- Pot Capacity: 2.5L
- Grill plate and hot pot for versatile cooking functions
- Detachable hot pot and grill plate for easy cleaning
- Cool touch base & handle
- Two adjustable temperature control knobs (Hot pot and Grill plate)
- Anti-slip feet design
- Cord storage
- Dimension of grill plate (mm): 290L x 230D x 24H
- Dimension of hot pot (mm): Ø22 x 77H
- Dimension of product (mm): 541L x 251D x 220H

RM239(WM) RM269(EM)
RRP: RM259(WM) RM289(EM)



Steamboat Function



Grill Feature



Removable Grill Pan for Easy Cleaning



Control Panel



PAN GRILL MPG-DA898NS

- Power rating: 1500-1800W
- Dual temperature control
- Oil free cooking for healthier meals

RM219(WM) RM229(EM)
RRP: RM239(WM) RM249(EM)



Grill Feature



Steamboat Function



Oil Drip Tray

TOASTER / BREAD MAKER



TOASTER MTS-32

- Power rating: 650W
- 2 slice pop-up toaster
- 6 levels adjustable browning control
- With cancel function
- With removable crumb tray
- Cord storage

RM53(WM) RM63(EM)
RRP: RM59(WM) RM69(EM)



TOASTER MTS-22A

- Power rating: 750W
- Auto bread centralizing feature
- Wider slot for thicker breads
- With dust cover
- With defrost, reheat, cancel functions & 7 levels of browning control.
- With crumb tray

RM62(WM) RM72(EM)
RRP: RM69(WM) RM79(EM)

BREAD MAKER MBM-1020

- Power: 550W
- Capacity: 2.0LBS
- Non-stick rectangle bread pan & kneading blade
- Adjustable crust control: Light, Medium and Dark
- Plastic body, LCD display
- 13-hour programmable delay function
- 10 minutes power off protection
- 60 minutes keep warm function

RM249(WM) RM289(EM)
RRP: RM269(WM) RM309(EM)



FOOD STEAMER



FOOD STEAMER MFS-29 NURISTEAM (BK) MFS-29 NURISTEAM (WH)

- Power: 1600W
- Capacity: 28L
- Come with double heaters
- Rice steaming container and water refill cup
- Stackable steam tray for easy storage
- Exterior water refill funnel with visible water level indicator
- Anti-dry thermostat protection
- 2 levels structure for convenient cooking
- 60 minutes timer with bell

RM309(WM) RM329(EM)
RRP: RM339(WM) RM359(EM)



Stackable for easy Storage



Removable Tray for Larger Steaming Compartment



Individual Steaming Compartment



Convenient Refill



Accessories



Removable Tray for Larger Steaming Compartment



3 levels structure to cook different foods



Stackable for easy Storage

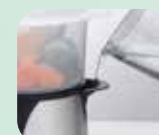

Convenient refill



1.5L Rice steaming container

FOOD STEAMER MFS-MC12L

- Power: 1000W
- Capacity: 12L
- Stainless steel housing
- Convenient refill
- Rice steaming container (1.5L x 1)
- Removable tray for larger steaming compartment
- Stackable for easy storage
- Visible water level
- Overheating protection
- 3 levels structure to cook different foods
- 60 minutes timer
- Cord storage, anti-slip feet

RM159(WM) RM169(EM)
RRP: RM169(WM) RM179(EM)



CUPCAKE/SANDWICH MAKER



3 IN 1 DETACHABLE SANDWICH MAKER MDM-383

- Power rating: 750W
- With detachable Sandwich plate, Waffle plate and Nut plate
- (BAHULU Egg Sponge Cakes)
- Non-stick coated plate for easy cleaning
- Automatic temperature control
- Horizontal & Vertical for compact storage and space saving
- With power and ready indicator light
- Anti-slip feet design
- Cool touch handle with lock
- Cord storage

RM109(WM) RM119(EM)
RRP: RM119(WM) RM129(EM)



Non-stick Coated Sandwich Plate



Non-stick Coated Nut Plate



Non-stick Coated Waffle Plate

SANDWICH MAKER MSM-SC150NS

- Power rating: 750W
- 2-Slice sandwich toasting plate
- Non-stick coated plate for easy cleaning
- Automatic temperature control
- High temperature for a perfectly toasted
- Horizontal & Vertical storage for space-saving
- Anti-slip feet design
- With power and ready indicator light
- Cool touch handle

RM53(WM) RM63(EM)
RRP: RM59(WM) RM69(EM)



THERMO POT/JUG KETTLE



THERMO POT MTP-266TSS

- Power rating: 1200-1428W
- Capacity: 6.0L
- SUS304 Stainless steel inner pot
- With safety lock function
- 5 Temperature control: 90°C, 80°C, 60°C, 40°C and Auto Cool
- Stainless steel steam vent
- Screwless design lid
- Unique base designed inner pot

RM179(WM) RM189(EM)
RRP: RM199(WM) RM209(EM)



JUG KETTLE MJK-G1120

- Rated wattage: 1850-2200W
- Capacity: 2.0L
- Transparent glass body
- Concealed heating plate with blue light ring
- Automatic Shut-off and Boil-dry Protection
- Cord storage

RM69(WM) RM79(EM)
RRP: RM79(WM) RM89(EM)



THERMO POT MTP-350TS

- Power rating: 1200-1428W
- Capacity: 5L
- 'SUS 304' stainless steel interior pot
- Screwless design lid
- Stainless steel steam venting hole
- Unique base designed inner pot

RM169(WM) RM179(EM)
RCP: RM189(WM) RM199(EM)



DOUBLE WALL JUG KETTLE MJK-G1117

- Rated wattage: 1850-2200W
- Capacity: 1.7L
- Transparent glass body
- Concealed heating plate with blue light ring
- Automatic Shut-off and Boil-dry Protection
- Cord storage

RM59(WM) RM69(EM)
RRP: RM69(WM) RM79(EM)



JUG KETTLE MJK-917

- Rated wattage: 1850-2200W
- Capacity: 1.7L
- Removable Filter For Easy Cleaning
- Stainless Steel Heating Element
- ON/OFF Switch with Light Indicator

RM44(WM) RM54(EM)
RRP: RM49(WM) RM59(EM)



Seamless SUS304 Stainless Steel Inner Pot



ON/OFF Switch with Indicator Light



DOUBLE WALL JUG KETTLE MJK-DW8218

- Rated wattage: 1850W
- Capacity: 1.8L
- SUS304 Stainless Steel Seamless Inner Pot For Easy Cleaning
- Colour Steel Cool Touch Exterior
- Automatic Shut-off and Boil-dry Protection
- ON/OFF Switch
- 360° Rotating Base

RM99(WM) RM109(EM)
RRP: RM109(WM) RM119(EM)

STAND MIXER



STAND MIXER MSM-SB1500

- Power rating: 1500W powerful motor, low noise
- 6.7L brushed stainless steel bowl
- Variable 8 stepless speed and pulse function

RM679(WM) RM699(EM)
RRP: RM749(WM) RM769(EM)



Dough Kneading



Egg Beating



Batter Mixing



Splashguard with Convenient Ingredients Inlet

STAND MIXER MSM-NC400HM

- Power rating: 400W
- Capacity: 3.5L mixer bowl
- 5 speeds with turbo function

RM149(WM) RM159(EM)
RRP: RM159(WM) RM169(EM)



STAND MIXER MSM-MIXTE 12

- Power rating: 1200W powerful motor
- 5.5L Stainless Steel Bowl
- Stepless speed and pulse function
- Non-slipping rubber feet
- Accessories: Whisk, Beater and Hook

RM399(WM) RM419(EM)
RRP: RM439(WM) RM459(EM)



Egg Whisking



Batter Mixing



Dough Kneading



Splash Guard with Convenient Ingredient Inlet



HAND MIXER MHM-MIXX 300

- Power rating: 300W
- 6 speeds with Turbo function
- With individual eject button
- Accessories: 2pcs stainless steel beater, 2pcs dough hook and 1pc of whisk
- With accessories storage box

RM59(WM) RM69(EM)
RRP: RM69(WM) RM79(EM)



INSTANT BOILER



INSTANT BOILER MIB-6620

- Power rating: 2000-2300W
- Capacity: 3.0L
- Removable transparent water tank with water level indicator for easy refilling and cleaning
- Digital LED Display and Touch Sensor Control
- Child Safety Lock
- 5 water dispensing settings: 100ml, 200ml, 300ml, 400ml & 000 (continuous flow).
- 7 temperature settings: 45°C, 55°C, 65°C, 75°C, 85°C, 100°C & 000 (normal temperature).
- One-touch presets: Milk (40°C) & Coffee (92°C).
- Error message E7 display with sound alert when water tank is empty.
- Removable water drip tray for easy cleaning.

RM319(WM) RM329(EM)
RRP: RM349(WM) RM359(EM)



Removable transparent water tank



One-touch presets: Milk (40°C)



Digital LED Display and Touch Sensor



One-touch presets: Coffee (92°C)

JUICE EXTRACTOR



JUICE EXTRACTOR MJE-SD400W

- Power rating: 400W
- Capacity: 600ml
- Durable Design: This juicer features a lightweight yet robust plastic body encased in a sleek stainless steel housing for added stability and a touch of elegance in your kitchen.
- Efficient Extraction: The 1L residue cup efficiently collects pulp, while the stainless steel filter with a plastic frame ensures maximum juice extraction and easy cleaning.
- Versatility and Convenience: The extra-large 65mm feeding tube accommodates a wider variety of fruits and vegetables, whole or cut into larger pieces, saving you prep time.
- Effortless Control: The two-speed control allows you to tackle both soft and hard ingredients with ease, while the secure lock

RM109(WM) RM119(EM)
RRP: RM119(WM) RM129(EM)



CERAMIC COOKER



CERAMIC COOKER MCC-2002

- Power rating: 2000W
- With stainless steel grill plate

RM169(WM) RM179(EM)
RRP: RM179(WM) RM189(EM)



Ideal for Stainless Steel Grill Plate or Pot



Ideal for Glassware



Ideal for Clay Pots



REFRIGERATOR



TWO DOOR REFRIGERATOR MRF-M7230 TD

Product Dimension(mm): 567L x 580D x 1460H

- Rated wattage: 70W
- Gross Capacity: 225L
- Frost Free Design
- Multi Air Flow cooling system
- Interior LED Light
- Electronic temperature control.
- Safety Glass Shelves
- 3 Door Balcony (Fridge); 2 Door Balcony (Freezer)
- Jumbo Fruit & Vegetable Box (with Humidity Control)
- Frameless design
- Anti-Bacterial Door Seal
- High energy efficiency compressor
- Fast & Efficient Cooling
- Fridge Temperature: 0°C ~ 10 °C
- Freezer Temperature: -5.7°C ~ -16°C
- Adjustable Front Legs
- Reversible door
- Compressor: 5 Years Warranty

RM1189(WM) RM1339(EM)
RRP: RM1319(WM) RM1469(EM)



REFRIGERATOR MRF-M7280 TD

Product Dimension(mm): 545L x 575D x 1695H

- Rated wattage: 80W
- Gross Capacity: 270L
- Frost Free Design
- Multi Air Flow cooling system
- Interior LED Light
- Electronic temperature control.
- Safety Glass Shelves
- 3 Door Balcony (Fridge); 2 Door Balcony (Freezer)
- Jumbo Fruit & Vegetable Box (with Humidity Control)
- Anti-Bacterial Door Seal
- High energy efficiency compressor
- Fast & Efficient Cooling
- Fridge Temperature: 0°C ~ 10 °C
- Freezer Temperature: -5.7°C ~ -16°C
- Adjustable Front Legs
- Reversible door
- Compressor: 5 Years Warranty

RM1339(WM) RM1509(EM)
RRP: RM1479(WM) RM1649(EM)

SINGLE DOOR REFRIGERATOR MRF-M7200 SD

Product Dimension(mm): 519L x 572D x 1292H

- Rated wattage: 80W
- Gross Capacity: 191L
- Semi-auto defrost
- Interior Lighting
- Easy-to-use mechanical temperature control.
- Separate chiller compartment
- Safety Glass Shelves
- 4 Door Balcony
- Jumbo Fruit & Vegetable Box
- Anti-Bacterial Door Seal
- High energy efficiency compressor
- Fast & Efficient Cooling
- Fridge Temperature: 0°C ~ 10 °C
- Freezer Temperature: -5.7°C ~ -16°C
- Adjustable Front Legs
- Reversible door

RM849(WM) RM969(EM)
RRP: RM939(WM) RM1059(EM)



SINGLE DOOR REFRIGERATOR MRF-M7110 SD

Product Dimension(mm): 474L x 445D x 830H

- Rated wattage: 60W
- Gross Capacity: 101L
- Easy-to-use mechanical temperature control.
- Separate chiller compartment
- 1 Safety Glass Shelves
- 3 Door Balcony
- Jumbo Fruit & Vegetable Box
- Anti-Bacterial Door Seal
- Reversible Door
- High energy efficiency compressor
- Fast & Efficient Cooling
- Fridge Temperature: 0°C ~ 10°C
- Freezer Temperature: -12.6°C ~ -17.8°C
- Adjustable Front Legs
- Reversible door
- Compressor: 5 Years Warranty

RM579(WM) RM639(EM)
RRP: RM639(WM) RM699(EM)



CHILLER SHOWCASE



"HEATING SYSTEM" can prevent fogging on the glass



CHILLER SHOWCASE MCS-850D

- Rated wattage: 410W
- Gross Capacity: 850L
- Digital Thermostat
- 4 Casters (70mm) + 1 Adjustable Leveling Leg
- Door Glass: Double Layer Tempered with Single Low-E film and Electric Heating (Electric Heating with ON/OFF function)
- With 2 Key Lock
- 8 Coated Wire Rack
- With 3 vertical LED light
- Self-evaporation water tray
- Frost Free
- Temperature: from 1°C to 10°C.
- Each shelf is able to hold up to: 25Kgs
- Compressor 5 year warranty

RM3949(WM) RM4339(EM)
RRP: RM4379(WM) RM4769(EM)



CHILLER SHOWCASE MCS-488

- Rated wattage: 330W
- Gross Capacity: 430L
- Frost Free
- Inner dimension(mm): 523W x 510D x 1565H
- Product dimension(mm): 606W x 665D x 2000H
- Temperature: 0°C to 10°C
- Each shelf is able to hold up to 36kgs

RM2879(WM) RM3129(EM)
RRP: RM3189(WM) RM3439(EM)

CHILLER SHOWCASE MCS-299

- Rated wattage: 210W
- Gross Capacity: 240L
- Adjustable Thermostat
- Adjustable Leveling Leg
- Double Glass Door (One with Tempered)
- With Key Lock
- 3 Coated Wire Rack
- Self-evaporation water tray
- Frost Free
- Temperature: from 0°C to 10°C.
- Each shelf is able to hold up to: 20Kgs
- Compressor 5 year warranty

RM1749(WM) RM1909(EM)
RRP: RM1939(WM) RM2099(EM)



CHILLER SHOWCASE MCS-339

- Rated wattage: 220W
- Gross Capacity: 280L
- Adjustable Thermostat
- Adjustable Leveling Leg
- Double Glass Door (One with Tempered)
- With Key Lock
- 4 Coated Wire Rack
- Self-evaporation water tray
- Frost Free
- Temperature: from 0°C to 10°C.
- Each shelf is able to hold up to: 20Kgs
- Compressor 5 year warranty

RM2199(WM) RM2369(EM)
RRP: RM2439(WM) RM2609(EM)



UPRIGHT FREEZER



UPRIGHT FREEZER MUF-EC318LW

Product Dimension(mm): 710L x 770D x 1570H

- Rated wattage: 180W
- Gross Capacity: 351L
- Inverter compressor
- Frost Free & Auto Defrost Functions
- CFC Free
- Fridge or Freezer Adjustable Thermostat
- Digital Touch Control Panel with LED display
- Easy to Clean 5 Freezer Compartments
- External Easy-open Handle
- LED Light
- Stay Organized and Easy Access
- Super Energy Saving
- Multi Airflow Design
- Child Lock function
- Fridge Temperature: 2°C ↔ 3°C ↔ 4°C ↔ 5°C ↔ 6°C ↔ 7°C ↔ 8°C
- Freezer Temperature: -16°C ↔ -17°C ↔ -18°C ↔ -19°C ↔ -20°C ↔ -21°C ↔ -22°C ↔ -23°C ↔ -24°C
- Compressor: 5 Years Warranty

RM2789(WM) RM3029(EM)
RRP: RM3099(WM) RM3339(EM)



UPRIGHT FREEZER MUF-EC278L

Product Dimension(mm): 600L x 660D x 1850H

- Rated wattage: 130W
- Gross Capacity: 307L
- Frost Free & Auto Defrost Functions
- CFC Free
- Precise Electronics Control Panel
- Easy to Clean 7 Freezer Compartments (3 shelves + 4 drawers)
- Freezer Door with 2 Shelf Bars
- External Easy-open Handle
- Deep and Quick Freezing
- High Energy Efficiency Compressor
- LED Light
- Required Less Floor Space
- Stay Organized and Easy Access
- Freezer Temperature: -14°C ~ -22°C
- Compressor: 5 Years Warranty

RM2569(WM) RM2799(EM)
RRP: RM2849(WM) RM3079(EM)

UPRIGHT FREEZER MUF-EC208L

Product Dimension(mm): 540L x 600D x 1710H

- Rated wattage: 140W
- Gross Capacity: 224L
- Frost Free & Auto Defrost Functions
- CFC Free
- Precise Electronic Control Panel
- Easy to Clean 6 Freezer Compartments (2 trays + 4 drawers)
- Recessed Handle
- Deep and Quick Freezing
- High Energy Efficiency Compressor
- Required Less Floor Space
- Stay Organized and Easy Access
- Freezer Temperature: -14°C ~ -22°C
- Compressor: 5 Years Warranty

RM1759(WM) RM1929(EM)
RRP: RM1949(WM) RM2119(EM)



MINI BAR



MINI BAR MMB-NB62LSL

- Capacity: 50L
- CFC Free
- Adjustable thermostat
- Product Dimension(mm): 475L x 450D x 487H

RM459(WM) RM499(EM)
RRP: RM509(WM) RM549(EM)



MINI BAR MMB-NC66(SL)

- Capacity: 50L
- CFC Free
- Adjustable thermostat
- Product Dimension(mm): 474L x 447D x 496aH

RM459(WM) RM499(EM)
RRP: RM509(WM) RM549(EM)

GLASS DOOR CHEST FREEZER

GLASS DOOR CHEST FREEZER MCF-G256L

Product Dimension(mm): 830L x 650D x 866H

- Gross Capacity: 256L
- CFC Free
- Epoxy Inner
- With Key Lock
- High Energy Efficiency Compressor
- Fridge or Freezer Adjustable Thermostat
- With 2 Baskets
- Fridge Temperature: 0°C to 10°C
- Freezer Temperature: -1°C to -18°C
- Maximum fit up to 2 Baskets

RM1429(WM) RM1579(EM)
RRP: RM1579(WM) RM1729(EM)

GLASS DOOR CHEST FREEZER MCF-G456L

Product Dimension(mm): 1434L x 651D x 800H

- Gross Capacity: 456L
- CFC Free
- Epoxy Inner
- With Key Lock
- High Energy Efficiency Compressor
- Fridge or Freezer Adjustable Thermostat
- With 2 Baskets
- Fridge Temperature: 0°C to 10°C
- Freezer Temperature: -1°C to -18°C
- Maximum fit up to 4 Baskets

RM1979(WM) RM2219(EM)
RRP: RM2189(WM) RM2429(EM)

GLASS DOOR CHEST FREEZER MCF-G336L

Product Dimension(mm): 1034L x 651D x 800H

- Gross Capacity: 336L
- CFC Free
- Epoxy Inner
- With Key Lock
- High Energy Efficiency Compressor
- Fridge or Freezer Adjustable Thermostat
- With 2 Baskets
- Fridge Temperature: 0°C to 10°C
- Freezer Temperature: -1°C to -18°C
- Maximum fit up to 3 Baskets

RM1649(WM) RM1819(EM)
RRP: RM1829(WM) RM1999(EM)

GLASS DOOR CHEST FREEZER MCF-G516L

Product Dimension(mm): 1630L x 650D x 866H

- Gross Capacity: 516L
- CFC Free
- Epoxy Inner
- With Key Lock
- High Energy Efficiency Compressor
- Fridge or Freezer Adjustable Thermostat
- With 2 Baskets
- Fridge Temperature: 0°C to 10°C
- Freezer Temperature: -1°C to -18°C
- Maximum fit up to 5 Baskets

RM2239(WM) RM2529(EM)
RRP: RM2479(WM) RM2769(EM)



CHEST FREEZER



5yrs Warranty COMPRESSOR
1yr Warranty GENERAL

CHEST FREEZER

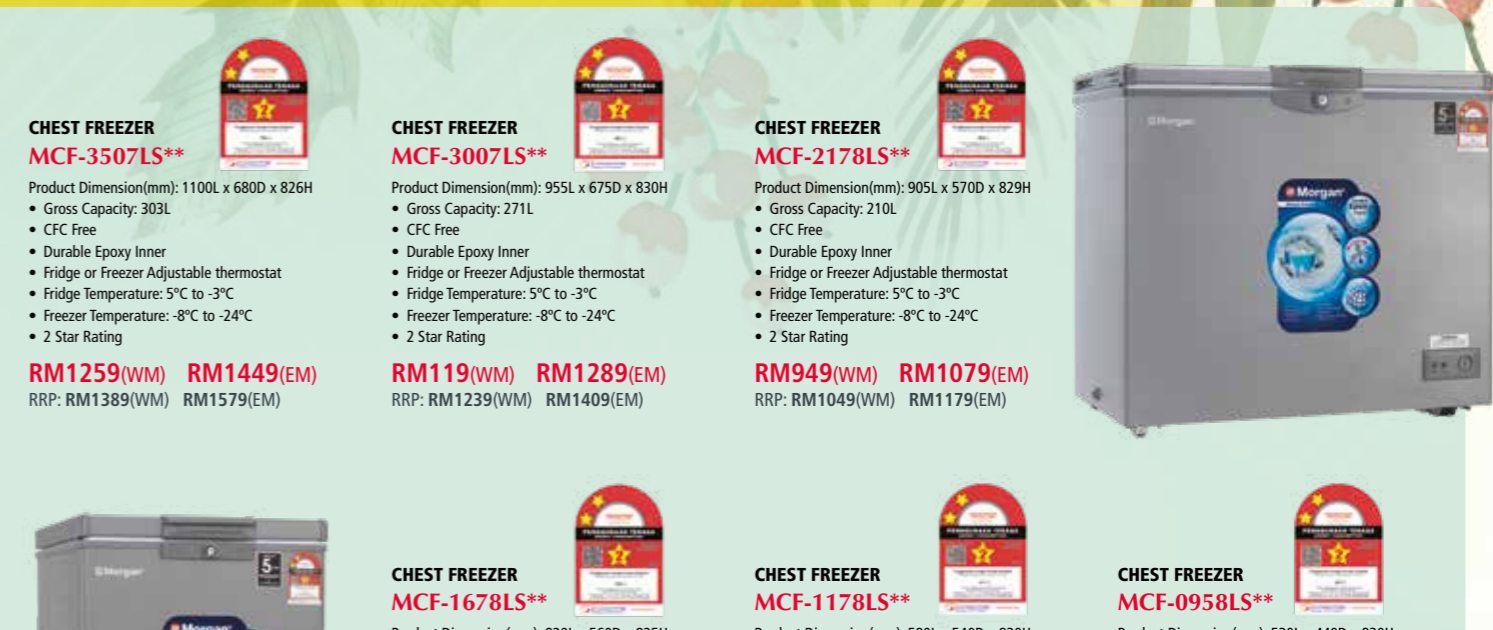

CHEST FREEZER
MCF-3507LS**
Product Dimension(mm): 1100L x 680D x 826H
• Gross Capacity: 303L
• CFC Free
• Durable Epoxy Inner
• Fridge or Freezer Adjustable thermostat
• Fridge Temperature: 5°C to -3°C
• Freezer Temperature: -8°C to -24°C
• 2 Star Rating
RM1259(WM) RM1449(EM)
RRP: RM1389(WM) RM1579(EM)

CHEST FREEZER
MCF-3007LS**
Product Dimension(mm): 955L x 675D x 830H
• Gross Capacity: 271L
• CFC Free
• Durable Epoxy Inner
• Fridge or Freezer Adjustable thermostat
• Fridge Temperature: 5°C to -3°C
• Freezer Temperature: -8°C to -24°C
• 2 Star Rating
RM119(WM) RM1289(EM)
RRP: RM1239(WM) RM1409(EM)

CHEST FREEZER
MCF-2178LS**
Product Dimension(mm): 905L x 570D x 829H
• Gross Capacity: 210L
• CFC Free
• Durable Epoxy Inner
• Fridge or Freezer Adjustable thermostat
• Fridge Temperature: 5°C to -3°C
• Freezer Temperature: -8°C to -24°C
• 2 Star Rating
RM949(WM) RM1079(EM)
RRP: RM1049(WM) RM1179(EM)



CHEST FREEZER
MCF-1678LS**
Product Dimension(mm): 820L x 560D x 825H
Gross Capacity: 175L
• CFC Free
• Durable Epoxy Inner
• Fridge or Freezer Adjustable thermostat
• Fridge Temperature: 5°C to -3°C
• Freezer Temperature: -8°C to -24°C
• 2 Star Rating
RM849(WM) RM949(EM)
RRP: RM939(WM) RM1039(EM)

CHEST FREEZER
MCF-1178LS**
Product Dimension(mm): 580L x 540D x 830H
• Gross Capacity: 116L
• CFC Free
• Durable Epoxy Inner
• Fridge or Freezer Adjustable thermostat
• Fridge Temperature: 5°C to -3°C
• Freezer Temperature: -8°C to -24°C
• 2 Star Rating
RM679(WM) RM759(EM)
RRP: RM749(WM) RM829(EM)

CHEST FREEZER
MCF-0958LS**
Product Dimension(mm): 530L x 440D x 830H
• Gross Capacity: 80L
• CFC Free
• Durable Epoxy Inner
• Fridge or Freezer Adjustable thermostat
• Fridge Temperature: 5°C to -3°C
• Freezer Temperature: -8°C to -24°C
• 2 Star Rating
RM629(WM) RM719(EM)
RRP: RM699(WM) RM789(EM)



CHEST FREEZER
MCF-7307L
Product Dimension(mm): 2030L x 725D x 910H
• Gross Capacity: 700L
• CFC Free
• 2 Doors
• Durable Epoxy Inner
• Fridge or Freezer Adjustable thermostat
• Fridge Temperature: 2°C to 10°C
• Freezer Temperature: -10°C to -20°C
RM3099(WM) RM3529(EM)
RRP: RM3439(WM) RM3869(EM)



CHEST FREEZER
MCF-6307L
Product Dimension(mm): 1800L x 760D x 827H
• Gross Capacity: 600L
• CFC Free
• 2 Doors
• Durable Epoxy Inner
• Fridge or Freezer Adjustable thermostat
• Fridge Temperature: 5°C to -3°C
• Freezer Temperature: -8°C to -24°C
RM2209(WM) RM2539(EM)
RRP: RM2449(WM) RM2779(EM)

CHEST FREEZER
MCF-5507L
Product Dimension(mm): 1600L x 765D x 826H
• Gross Capacity: 520L
• CFC Free
• 2 Doors
• Durable Epoxy Inner
• Fridge or Freezer Adjustable thermostat
• Fridge Temperature: 5°C to -3°C
• Freezer Temperature: -8°C to -24°C
RM2119(WM) RM2419(EM)
RRP: RM2349(WM) RM2649(EM)



CHEST FREEZER
MCF-4507L
Product Dimension(mm): 1440L x 680D x 826H
• Gross Capacity: 423L
• CFC Free
• Durable Epoxy Inner
• Fridge or Freezer Adjustable thermostat
• Fridge Temperature: 5°C to -3°C
• Freezer Temperature: -8°C to -24°C
RM1749(WM) RM1999(EM)
RRP: RM1939(WM) RM2189(EM)



CHEST FREEZER
MCF-EVEREST 210
Product Dimension(mm): 545L x 476D x 835H
• Gross Capacity: 207L
• CFC Free
• Epoxy Inner
• With Key Lock
• Deep and Quick Freezing
• High Energy Efficiency Compressor
• Easy to Clean
• Fridge or Freezer Adjustable Thermostat
• Coated Wire Basket
• Compressor: 5 Year Warranty
• Fridge Temperature: 2.2°C ~ -2.5°C
• Freezer Temperature: -16°C ~ -27°C
RM679(WM) RM749(EM)
RRP: RM749(WM) RM819(EM)



CHEST FREEZER
MCF-EVEREST 215
Product Dimension(mm): 635L x 556D x 835H
• Gross Capacity: 150L
• CFC Free
• Epoxy Inner
• With Key Lock
• Deep and Quick Freezing
• High Energy Efficiency Compressor
• Easy to Clean
• Fridge or Freezer Adjustable Thermostat
• Coated Wire Basket
• Compressor: 5 Year Warranty
• Fridge Temperature: 3°C ~ -2°C
• Freezer Temperature: -19°C ~ -30°C
RM779(WM) RM869(EM)
RRP: RM859(WM) RM949(EM)

CHEST FREEZER
MCF-EVEREST 220
Product Dimension(mm): 823L x 556D x 835H
• Gross Capacity: 207L
• CFC Free
• Epoxy Inner
• With Key Lock
• Deep and Quick Freezing
• High Energy Efficiency Compressor
• Easy to Clean
• Fridge or Freezer Adjustable Thermostat
• Coated Wire Basket
• Compressor: 5 Year Warranty
• Fridge Temperature: 2.2°C ~ -2.5°C
• Freezer Temperature: -16°C ~ -27°C
RM949(WM) RM1069(EM)
RRP: RM1049(WM) RM1169(EM)

CHEST FREEZER
MCF-EVEREST 230
Product Dimension(mm): 1125L x 610D x 835H
• Gross Capacity: 150L
• CFC Free
• Epoxy Inner
• With Key Lock
• Deep and Quick Freezing
• High Energy Efficiency Compressor
• Easy to Clean
• Fridge or Freezer Adjustable Thermostat
• Coated Wire Basket
• Compressor: 5 Year Warranty
• Fridge Temperature: 3°C ~ -2°C
• Freezer Temperature: -19°C ~ -30°C
RM1189(WM) RM1359(EM)
RRP: RM1319(WM) RM1489(EM)



FOOD PROCESSOR/CHOPPER



FOOD PROCESSOR/CHOPPER MCP-30P

- Power rating: 300W
- 4 stainless steel blades
- Multifunction peeler (to peel garlic and peanut)
- 1.2L capacity of glass bowl
- 4D glass bowl design (allows the upper and lower blades to chop food evenly)
- With safety operation design
- User-friendly design

RM99(WM) RM109(EM)
RRP: RM109(WM) RM119(EM)



AIR COOLER



AIR COOLER MAC-CX10DW

- Power: 65W
- Large water tank capacity: 10L
- Air flow: 1100m³/hr
- Suitable for room size up to 15m² - 20m²
- Durable Honeycomb filter with dust proof cover
- 3 in 1 Air Cooler / Air Purifier / Humidifier
- 2 cooler packs
- 3 speed selection (L/M/H)
- Removable water tank
- With casters

RM219(WM) RM239(EM)
RRP: RM239(WM) RM259(EM)



AIR COOLER MAC-COOL7A

- Power: 90W
- Large water tank capacity: 35L
- Air flow: 3000m³/hr
- Suitable for room size up to 20-30m²
- 3-Sided Durable honeycomb filter for Max Cooling with dust proof cover
- LED Display With touch Control
- Timer Setting Function Up to 12 Hours
- 2 Cooler Packs

RM599(WM) RM659(EM)
RRP: RM659(WM) RM719(EM)



AIR COOLER MAC-CX12

- Power: 65W
- Large water tank capacity: 12L
- Air flow: 1150m³/hr
- Suitable for room size up to 20m²
- Durable Honeycomb Filter with Dust Proof Cover
- 4 Cooler Packs

RM289(WM) RM329(EM)
RRP: RM319(WM) RM359(EM)



PORTABLE AIR COND



PORTABLE AIR-COND MAC-093 Lite

- Cooling capacity: 9000btu/hr (2.61kw)
- Suitable for room size up to 14-20m²
- Washable filters
- Auto left & right swing louvers
- Automatic Evaporative system
- 3 in 1 function of Cooling/Dehumidifying/Fan
- High & Low Fan Speeds
- 24 Hour ON/OFF Timer
- With Remote Control

RM989(WM) RM1099(EM)
RRP: RM1089(WM) RM1199(EM)



PORTABLE AIR-COND MAC-121 SIERRAIRE

- Cooling capacity: 12000btu/hr (3500W)
- Suitable for room size up to 25-30m²
- Auto Up/Down Swing Louvers
- Automatic Evaporative System
- 3-in-1 Function of Cooling, Dehumidifying and Fan
- With LOW/MID/HIGH Fan Speeds
- 24 hour ON/OFF Timer
- With Remote Control

RM1529(WM) RM1669(EM)
RRP: RM1699(WM) RM1839(EM)



CIRCULATION FAN



CIRCULATION FAN MFQ-D3RC

- Power: 105W
- Fan Blades: Ø8"
- Three Independent fan with 3 speed control.
- Adjustable tilt position.
- Auto Oscillation for left and right.
- Manual Oscillation for up and down.
- Timer setting up to 7 hours
- With remote control
- Easy dismantle for cleaning

RM409(WM) RM439(EM)
RRP: RM449(WM) RM479(EM)



CIRCULATION FAN MFQ-SC61M

- Power: 60W
- Fan size: Ø265mm
- Fan blades size: Ø228mm
- Mechanical control
- Easy detachable front net cover for cleaning
- 4 setting speeds
- Left and right auto-oscillation angle up to 65°
- Up and down auto-oscillation angle up to 85°

RM199(WM) RM209(EM)
RRP: RM219(WM) RM229(EM)

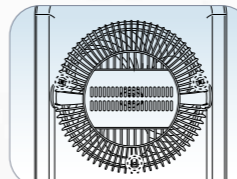

Remove the power plug from the power supply before disassembling the fan for cleaning. Remove the three screws from the back cover.

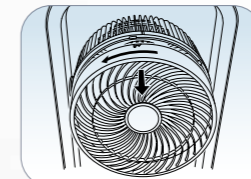

Twist the front cover to the left to detach it.

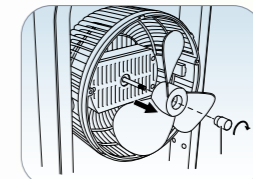

Twist the fan blade screw to the right and detach the fan blade. Proceed to clean the fan blade.



STAND/WALL FAN



WALL FAN
MWF-180M

- Power rating: 80W
- With 6 PP Fan Blade
- Wider and High Air Delivery
- 3 Speed Setting
- Smooth Oscillation
- Flexible neck adjustment
- Stronger Fan Guard with Reinforcement Ring
- Equipped with a durable 100% Copper Motor
- Built-in Safety Thermal Fuse

RM169(WM) RM189(EM)
RRP: RM179(WM) RM199(EM)

WALL FAN
MWF-NC169RC

- Power rating: 50W
- 3 AS Fan Blade
- High Quality & Durable copper motor
- Smooth Oscillation
- 3 Speed mode
- 12 Hours Timer
- Comes with Remote Control
- Convenient Guard Ring Clip

RM149(WM) RM159(EM)
RRP: RM159(WM) RM169(EM)



WALL FAN
MWF-NC168MS

- Power rating: 45W
- Thermal safety fuse
- High Quality & Durable Motor
- Smooth Oscillation
- 3 Speed Mode

RM129(WM) RM149(EM)
RRP: RM139(WM) RM159(EM)



STAND FAN
MSF-16P5

- Power rating: 50W
- 5 AS Fan Blade
- Pure copper motor
- Smooth Oscillation
- 3 Speed mode
- 2 Hours Timer

RM139(WM) RM149(EM)
RRP: RM149(WM) RM159(EM)



VENTILATION FAN

VENTILATION FAN
MVF-WA120

- Power rating: 45W
- Wall Mounted Type
- For Shop, Office Room, Living Room & Kitchen
- Elegant Design
- Powerful Motor
- Fan size: 300mm

RM77(WM) RM91(EM)
RRP: RM85(WM) RM99(EM)

VENTILATION FAN
MVF-WA100

- Power rating: 35W
- Wall Mounted Type
- For Shop, Office Room, Living Room & Kitchen
- Energy Efficient
- Powerful Motor
- Fan size: 250mm

RM80(WM) RM90(EM)
RRP: RM89(WM) RM99(EM)



VENTILATION FAN
MVF-WA80

- Power rating: 30W
- Wall Mounted Type
- For Shop, Office Room, Living Room & Kitchen
- Energy Efficient
- Powerful Motor
- Fan size: 200mm

RM62(WM) RM72(EM)
RRP: RM69(WM) RM79(EM)



VENTILATION FAN
MVF-CA12XS

- Power rating: 30W
- Ceiling Mounted Type
- For Shop, Office Room, Living Room & Kitchen
- Elegant Design
- Energy Efficient
- Fan size: 120mm

RM77(WM) RM81(EM)
RRP: RM85(WM) RM89(EM)



VENTILATION FAN
MVF-CB12XW

- Power rating: 30W
- Ceiling Mounted Type
- For Shop, Office Room, Living Room & Kitchen
- Elegant Design
- Energy Efficient
- Fan size: 120mm

RM89(WM) RM99(EM)
RRP: RM99(WM) RM109(EM)



GARMENT STEAMER



GARMENT STEAMER
MSI-GB206

- Power: 1350-1650W
- Stainless Steel Steam Panel
- Powerful Steam
- Translucent 2.0L water tank
- Steam rate 32g/min

RM199(WM) RM219(EM)
RRP: RM219(WM) RM239(EM)



Stainless Steel Steam Panel with Powerful Steam



Fabric Brush



Rotatable & Collapsible Hanger



Little Helper - for Easy Ironing



Accessories

TUMBLE DRYER



TUMBLE DRYER MTD-SENSDRY 8

- Power rating: 1700W
- Capacity: 7Kg
- Dryer type: Venting
- Electronic control
- LED display
- 16 drying programs: Extra Dry, Standard Dry, Mix Dry, Airing, Iron Dry, Quilt, Towels, Shake the Quilt, Sportswear, Jeans, Fiber, 2.5 hours, 2 hours, 1.5hours, 1 hour, 30 mins.
- Heat Setting: Full heating, Half heating and Airing.
- Crease Guard (Anti-Crease function to reduce wrinkling.)
- Delay timer: 1 – 12 hours
- Front lint filter
- Child lock indicator and Error alarm.

RM1079(WM) RM1169(EM)
RRP: RM1199(WM) RM1289(EM)



Front Lint Filter



LED Display



Hot Air Vent Hose

FRONT LOAD WASHER DRYER



FRONT LOAD WASHER DRYER MWD-SPACEPRO 10CB

- Washing power rating: 2000W
- Drying power rating: 1600W
- Washing Capacity: 10Kg
- Drying Capacity: 6Kg
- Wash & Dry Combo
- Extra Slim Body design
- Ozone sterilization function
- 16 Washing Programmers
- Washing Temperature: Cold, 20°C, 40°C, 60°C, 80°C, 85°C
- ECS system "Reduce vibration and running noise by correcting polarization timely."
- M-smart: One key to start the washing mode
- Door Lock & Child Safety Lock Display

RM1799(WM) RM1899(EM)
RRP: RM1999(WM) RM2099(EM)



SEMI AUTO WASHING MACHINE



SEMI AUTO WASHING MACHINE MWM-B1370SA

- Washing Capacity: 7.0Kg
- Spinning Capacity: 5.0Kg
- Washing power: 350W
- Spinning power: 160W
- Anti-rat Base Design
- With Lint Filter

RM499(WM) RM579(EM)
RRP: RM549(WM) RM629(EM)



SEMI AUTO WASHING MACHINE MWM-B1310SA

- Washing Capacity: 10.0Kg
- Spinning Capacity: 6.5Kg
- Washing power: 380W
- Spinning power: 180W
- Anti-rat Base Design
- With Lint Filter

RM649(WM) RM769(EM)
RRP: RM719(WM) RM839(EM)

SEMI AUTO WASHING MACHINE MWM-B1312SA

- Washing Capacity: 12.0Kg
- Spinning Capacity: 6.5Kg
- Washing power: 420W
- Spinning power: 180W
- Anti-rat Base Design
- With Lint Filter

RM769(WM) RM909(EM)
RRP: RM849(WM) RM989(EM)



FULLY AUTO WASHING MACHINE MWM-TANZANITE 10TL

- Washing Capacity: 10.0Kg
- Spinning Capacity: 10.0Kg
- Washing power: 525W
- Stainless Steel Drum
- Transparent Tempered Glass Lid
- LED display panel
- Magic cleaning filter
- Anti-rat base design (Base cover)
- Power Off Memory
- Powerful & Durable Motor for Efficient Washing
- With Adjustable foot
- With Detergent Dispenser
- Fuzzy Control
- Functions: Delay End, ONE TOUCH, Child Lock
- With 7 program selection

RM1069(WM) RM1169(EM)
RRP: RM1179(WM) RM1279(EM)



FULLY AUTO WASHING MACHINE MWM-TANZANITE 7TL

- Washing Capacity: 7.0Kg
- Spinning Capacity: 7.0Kg
- Rated power: 360W
- Stainless Steel Drum
- Transparent Plastic Lid
- Rust-proof plastic body
- LED display panel
- Magic cleaning filter
- Anti-rat base design (Base cover)
- Power Off Memory
- Powerful & Durable Motor for Efficient Washing
- With Adjustable foot
- Fuzzy Control
- Functions: Delay End, ONE TOUCH, Child Lock
- With 10 program selection

RM719(WM) RM799(EM)
RRP: RM789(WM) RM869(EM)



FULLY AUTO WASHING MACHINE MWM-TANZANITE 8TL

- Washing Capacity: 8.0Kg
- Spinning Capacity: 8.0Kg
- Rated power: 495W
- Stainless Steel Drum
- Transparent Plastic Lid
- LED display panel
- Magic cleaning filter
- Anti-rat base design (Base cover)
- Power Off Memory
- Powerful & Durable Motor for Efficient Washing
- With Adjustable foot
- Fuzzy Control
- Functions: Delay End, ONE TOUCH, Child Lock
- With 7 program selection

RM879(WM) RM969(EM)
RRP: RM969(WM) RM1059(EM)



FULLY AUTO WASHING MACHINE MWM-13 AQUAMARINE

- Washing Capacity: 13.0Kg
- Spinning Capacity: 13.0Kg
- Washing power: 410W
- Spinning power: 330W
- Stainless Steel Drum
- Magic Cleaning Filter
- Tempered Glass Transparent Lid
- With delay wash function
- Child Lock
- With Detergent drawer Compartment
- Fuzzy Control function
- Anti-Rat Base Design
- Powerful & Durable Motor for Efficient Washing
- With 9 program selection

RM1299(WM) RM1429(EM)
RRP: RM1439(WM) RM1569(EM)



FULLY AUTO WASHING MACHINE MWM-7 ZIRCON

- Washing Capacity: 7.0Kg
- Spinning Capacity: 7.0Kg
- Washing power: 325W
- Spinning power: 250W
- Stainless Steel Drum
- Magic Cleaning Filter
- Foldable transparent lid
- Anti-Rat Base Design
- With Memory Back Up Function
- Powerful & Durable Motor for Efficient Washing
- With 8 program selection

RM719(WM) RM819(EM)
RRP: RM789(WM) RM889(EM)

NEW

5 Years MOTOR WARRANTY

3 Years PC BOARD WARRANTY

2 Years PARTS & LABOUR WARRANTY



Motorized Dust Mite Brush



Ellipse Brush Easily Remove Dirt



Crevice Tool Clean Hard To Reach Places



Power Brush with LED Light



Crevice Tool with Flexible Hose



Accessories



Power Brush with 180° Swivels sideways and 90° up and down



Detachable & Washable Filter



Washable Fiber Filter



LED Control Panel



Hanger with Charger



Cordless 3 In 1 Stick/Handheld Vacuum Cleaner MVC-CHS198DB

- Power rating: 450W
- Dust capacity: 0.5L
- Digital screen
- Charging time: 5 Hours
- Suction pressure: ≥120AW
- Detachable and Rechargeable 2000mAh Lithium-Ion Battery
- 25000PA (High speed) / 14000PA (Middle speed) / 9000PA (Low speed)
- LED Front Light Multi-tasker Power Brush with 180° Swivels sideways and 90° up and down for convenient handling in corners and around obstacles.
- Operating time: 12 minutes (High speed), 25 minutes (Middle speed), 50 minutes (Low speed)
- Washable bagless dust container with cyclone stainless steel mesh filter
- Convenient and hygienic dust bucket emptying
- Three speed control for effective and thorough cleaning on various occasions
- Accessories: Mini turbo dust mite brush, 2 in 1 dusting brush, Crevice tool and Flexible hose.

RM659(WM) RM669(EM)
RRP: RM729(WM) RM739(EM)

UPRIGHT VACUUM CLEANER MVC-CYCLONE 60

- Power rating: 600W
- Max Suction 150W, Max Vacuum 16 -18.72kpa
- Capacity: 1.2L
- Noise level ≤73dB
- Upright and Handheld dual-usage
- With 2 stages filtering system
- Bagless design, simple dust disposal
- Detachable and extendable handle for different height level
- With 5 meter of power cord
- Compact size and easy storage
- Accessories: Dual function suction nozzle

RM109(WM) RM119(EM)
RRP: RM119(WM) RM129(EM)



- This Cyclone Filter come with separation technology of dust and dirt to result optimal performance of the vacuum.
- It uses the principle of cyclone separation to pull dust and dirt to the bottom of the dust cup without blocking its performance.
- This is washable Cyclone filter.



Swivel Floor Brush for Easy Floor Cleaning



Ellipse Brush Easily Removes Stubborn Dirt



Crevice Tool Cleans Tight Places



Cyclone Filter



Washable Filter

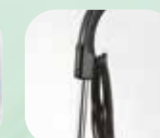

Convenient Cord Storage





Exclusive Dealer:

- Offer valid while stocks last
- Prices shown are not valid for redemption project & duty-free sales
- We reserve the right to alter, modify or replace the product price, specifications & models without prior notice
- All items featured in this catalogue may differ from the actual product in terms of colour & design details
- The recommended resale price is the price which the importer recommends that the retailer sell the product. Retailers are able to independently set the retail price.

*RRP = Recommended resale price

Market Expansion
Services by
www.dksh.com.my



DKSH Malaysia Sdn Bhd 196101000441 (4476-U)
B-11-01, The Ascent Paradigm,
No. 1, Jalan SS7/26A, Kelana Jaya,
47301 Petaling Jaya, Selangor Darul Ehsan.
Tel: +603 7882 8888 Fax: +603 7882 5555
www.morgan.my

Customer Care Hotline: **03-7781 9229**



facebook.com/morganappliances