

 **Mórgan®**

 **Mórgan®**

Market Expansion
Services by
www.dksh.com



DKSH

E-mail: electrical.appliance@dksh.com
www.morgan.my

USER MANUAL

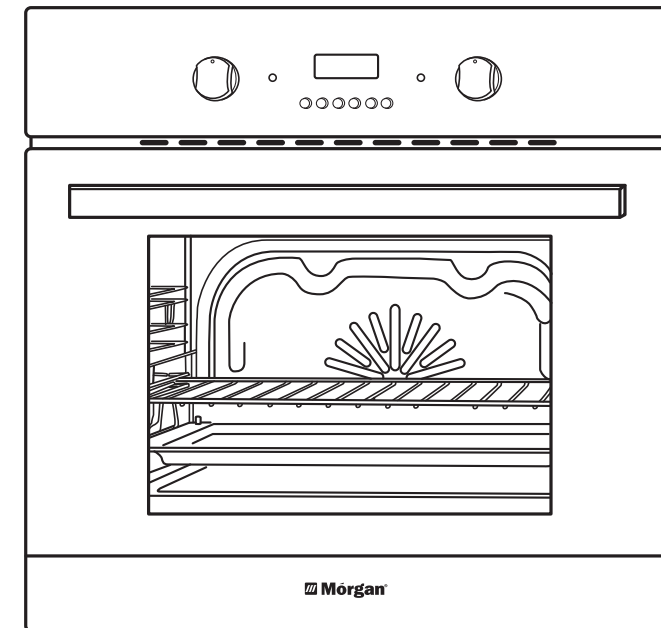

Built-in Oven

MBO-SA701TE

C O N T E N T S

4-5 Important Safety Information

5 Specifications

6 Control Panel

6-9 Setting And Using The Oven Programmer/Timer

9-11 Operating Instructions

12 Cleaning And Maintenance

12 Removable Oven Roof Liner

12 Replacing The Oven Bulb

13-14 Installation

15-16 Troubleshooting

16-17 Main Cooking Functions Guideline

TROUBLESHOOTING

DO NOT ATTEMPT TO REPAIR THE APPLIANCE YOURSELF.

- Please note that if an engineer is asked to attend whilst the product is under guarantee and finds that the problem is not the result of an appliance fault, then you may be liable for the cost of the service call.
- The appliance must be accessible for the engineer to perform any necessary repair. If your appliance is installed in such a way that an engineer is concerned that damage will be caused to the appliance or your kitchen, then he will not complete a repair.
- This includes situations where appliances have been tiled in, sealed in with sealant, have wooden obstructions placed in front of the appliance, like plinths. Or any installation other than the one specified by our company has been completed.

MAIN COOKING FUNCTIONS GUIDELINE



REAR HEATING ELEMENT + FAN

Food	Weight	Preheat time	Tray position	Temperature setting	Finish time
Beef	1.0 kg	15 min	2nd layer	200°C	40-50 min
Chicken	1.2 kg	15 min	2nd layer	200°C	50-60 min
Steak	0.8 kg	10 min	2nd layer	180°C	20-30 min
Bread	0.5 kg	10 min	2nd layer	200°C	35-45 min



TOP HEATING ELEMENT + BOTTOM HEATING ELEMENT

Food	Weight	Preheat time	Tray position	Temperature setting	Finish time
Beef	1.0 kg	15 min	2nd layer	220°C	40-50 min
Chicken	1.2 kg	15 min	2nd layer	220°C	50-60 min
Steak	0.8 kg	10 min	2nd layer	220°C	20-30 min
Bread	0.5 kg	10 min	2nd layer	220°C	35-45 min



TOP HEATING ELEMENT + FAN

Food	Weight	Preheat time	Tray position	Temperature setting	Finish time
Steak	0.8 kg	10 min	3rd layer	200°C	20-25 min
Chicken	1.2 kg	10 min	3rd layer	200°C	40-45 min
Sausage	0.6 kg	10 min	3rd layer	200°C	15-20 min
Hamburger	0.6 kg	10 min	3rd layer	200°C	15-20 min
Corn	1.2 kg	10 min	3rd layer	200°C	20-25 min
Vegetable	0.5 kg	10 min	4th layer	200°C	15-20 min

CLEANING

It is recommended to clean the oven regularly

- Care should be taken whilst using this appliance and when following the cleaning procedure.
- **IMPORTANT:** The appliance must be disconnected from the power supply before following the cleaning procedure.

INSTALLATION

This appliance must be correctly installed by a suitably qualified person, strictly in accordance with the manufacturer's instructions.

- We decline any responsibility for injury or damage, to person or property, as a result of improper use or installation of this appliance.
- Heat, steam and moisture will be created while using this appliance. Ensure that the room is adequately ventilated so as to avoid injury. If the appliance is going to be used for prolonged periods of time, then additional ventilation may be required.
- Please consult with your qualified installer if you have any doubts about the amount of ventilation that you will require.

SPECIFICATIONS

Model	MBO-SA701TE
Dimensions (mm)	590H x 595W x 550D
Rated Voltage / Frequency	220-240V~ 50Hz
Rated Wattage	2400W
Power Supply Connection	13A (double pole switched fused outlet with 3mm contact gap)
Mains Supply Lead:	3 x 1.5mm²
Oven Light Bulb	25 W/300°C screw type pigmy
Oven Capacity	57 Litres

- 7 functions
- Thermostatically controlled grill

COOLING FAN

- A tangential cooling fan is fitted inside this appliance to stabilise the internal temperature of the oven and to cool the external surface temperature. Immediately after use, the cooling fan will continue operating and automatically turn off when the oven has sufficiently cooled down.

INSTALLATION

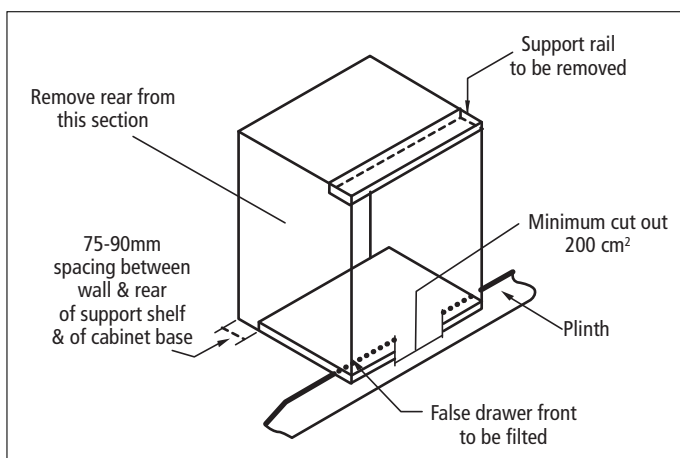

Figure shows the ventilation and cut-out requirements for the installation of the appliance into a standard kitchen unit.

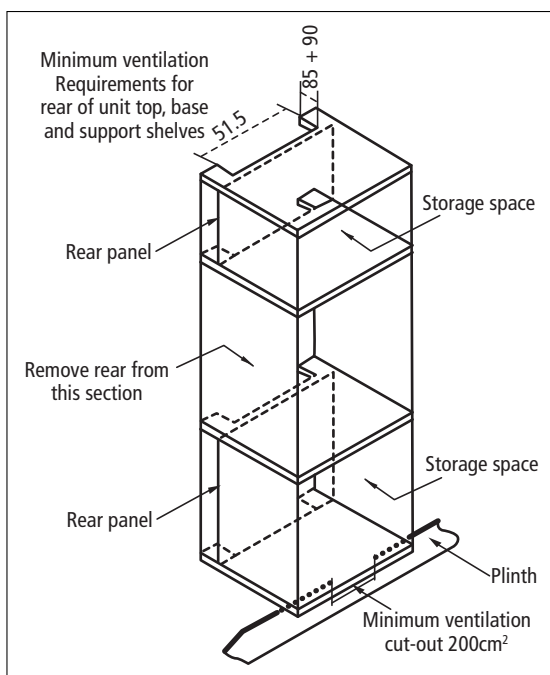
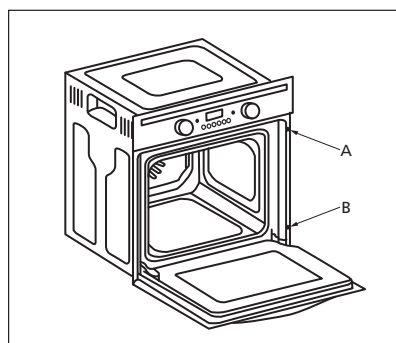

Figure shows the ventilation and cut-out requirements for the installation of the appliance into a tall housing unit.



Ensure that the oven has been securely fixed into the housing unit. The fixing of the oven into the housing is made by using four screws. These should be screwed through the oven cabinet and into the housing unit.

SETTING AND USING THE OVEN PROGRAMMER/TIMER

SETTING THE MINUTE MINDER FUNCTION

You are able to set the minute minder at any time, regardless of whether an oven function has been selected. You can select a preset time using the minute minder function and an alarm will sound when that period of time has elapsed.

- Press the "minute minder" button (6), the display will show a value of 00:00. Set the period of time that you wish the minute minder to countdown by using the "minus" (10) and "plus" (11) buttons.
- Once the display shows the desired countdown time, release the "minus" and "plus" buttons. The minute minder symbol (13) will appear on the timer display.
- Once a countdown time has been set, it is possible to increase or decrease the time by using the "minus" or "plus" buttons.
- An alarm will sound when the countdown time has elapsed. The alarm can be silenced by pressing the "minute minder" button.
- **IMPORTANT:** The oven will continue to heat once the alarm has been silenced. If you have finished cooking, then you should turn the oven function selector and thermostat control knob to '0'.

SETTING THE DURATION FUNCTION

This function will allow you to set a countdown time similar to the minute minder function. However the oven will no longer continue to heat once the countdown period has elapsed.

- Use the thermostat control knob (3) to set the temperature that you require. The manual operation symbol (14) will appear on the display.
- Use the oven function selector knob (1) to select the mode of cooking that you require.
- It is then possible to set the countdown time that you require.
- Press the "duration" button (7) and the display will show a value of 00:00. Set the countdown time by using the "minus" (10) and "plus" (11) buttons.
- Once the display shows the desired countdown time, release the "minus" and "plus" buttons. Countdown will begin immediately and the word AUTO will appear on the timer display.
- Once a countdown time has been set, it is possible to increase or decrease the time by using the "minus" or "plus" buttons.
- An alarm will sound when the countdown time has elapsed and the oven will switch off. The word AUTO will flash and the heating symbol will disappear. The alarm can be silenced by pressing the "duration" button.
- You will need to reset the oven to manual operation mode once the duration function has been used. To do this - press the "manual operation" button, the word AUTO will disappear from the display and the manual operation symbol will appear instead.
- **IMPORTANT:** If you do not turn the thermostat control knob and oven function selector knob to 0, then the appliance will continue to operate as soon as you press the "manual operation" button.

CLEANING AND MAINTENANCE

Cleaning operations must only be carried out when the oven is cool. The appliance should be disconnected from your mains supply before commencing any cleaning process.

- The oven should be thoroughly cleaned before using it for the first time and after each use. This will avoid residual food from caking the oven cavity. After residues have been baked on several times, they are more difficult to remove.
- Never clean the oven surfaces by steam cleaning.
- The oven cavity should only be cleaned with warm soapy water, using either a sponge or soft cloth. Avoid using abrasive cleaners.
- Any stains that may appear on the bottom of the oven are originated from food splashes or spilt food, these splashes occur during the cooking process.
- These could possibly be a result of the food being cooked at an excessively high temperature or being placed in cookware that is too small.
- You should select a cooking temperature and function that is appropriate for the food that you are cooking. You should also ensure that the food is placed in an adequately sized dish and that you use the drip tray where appropriate.
- Outer parts of the oven should only be cleaned with warm soapy water, using either a sponge or soft cloth. Never use abrasive cleaners.
- If you use any form of oven cleaner on your appliance, then you must check with the manufacturer of the cleaner that it is suitable for use on your appliance.
- Any damage to the appliance caused by inappropriate cleaning product will nullify the product warranty.

REMOVABLE OVEN ROOF LINER

- Your appliance is supplied with a roof liner, which should be slid over the top of the grill element.
- Once you have finished cooking, the liner should be removed and thoroughly cleaned after each use of the appliance.
- Do not allow fat and grease to build up on the oven liner, as this could cause a fire hazard.

REPLACING THE OVEN BULB

IMPORTANT: Ensure oven is disconnected from the power supply before attempting to either remove or replace the oven bulb.

- Turn the lamp cover anti-clockwise to unscrew it.
- Turn the bulb anti-clockwise to unscrew and remove it from the holder.
- Replace the bulb with a 25 W/300°C, screw type pigmy.
- Do not use any incompatible other bulbs.
- Assemble the lamp cover back into position before connecting appliance to the power supply.

SELECTING A COOKING FUNCTION AND TEMPERATURE

SELECTING MANUAL OPERATION MODE

After the appliance is connected to the power supply for the first time, the numbers on the timer display will flash. Before you can select a cooking function or set a temperature, you must set the appliance into "manual operation" mode.

- To select manual operation mode, press the "manual operation" button (9) on the control panel.

SELECTING AN OVEN FUNCTION

The oven function selector knob should be used to select the particular mode of cooking that you require. The appliance will utilise different elements within the oven cavity, depending on the oven function that you select. When a function is selected, the power indicator light will come on.

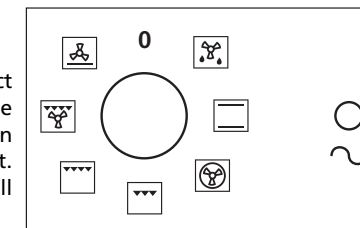

OPERATING INSTRUCTIONS

SEVEN FUNCTIONS OF THIS OVEN CAN BE SELECTED FOR BARBEQUE



DEFROST: The fan runs without heat to reduce the defrosting time of frozen foods. The time required to defrost the food will depend on the room temperature, the quantity and type of food.



FULL GRILL: This method of cooking utilises the inner and outer parts of the top element, which directs heat downwards onto the food. This function is suitable for grilling medium or large portions of sausages, bacon, steaks, fish etc.



HALF GRILL: This method of cooking utilises the inner part only of the top element, which directs heat downwards onto the food. This function is suitable for grilling small portions of bacon, toast and meat etc.



FAN AND BOTTOM ELEMENT: This method of cooking utilises the bottom element in conjunction with the fan, which helps to circulate the heat. This function is suitable for sterilizing and preserving jars.



CONVENTIONAL OVEN (top and lower element): This traditional cooking method provides with heat from the top and lower elements and is suitable for roasting and baking on one shelf only.



FAN AND GRILL: This method of cooking utilises the top element in conjunction with the fan, which helps to provide a quick circulation of heat. This function is suitable where quick browning is required and "sealing" the juices in, such as steaks, hamburgers, some vegetables etc.



FAN OVEN: This method of cooking uses the circular element whilst the heat is distributed by the fan. This results in a faster and more economical cooking process. The fan oven allows food to be cooked simultaneously on different shelves, preventing the transmission of odours and tastes from one dish onto another.

OPERATING INSTRUCTIONS

THERMOSTAT CONTROL KNOB

- The oven thermostat control knob sets the required temperature of the oven. It is possible to regulate the temperature within a range of 50 - 250°C.
- Turn the control knob clockwise.

OVEN OPERATING LIGHT

- This light will illuminate to indicate that the oven's heating elements are in operation. The light will turn off when the temperature set on the thermostat control knob has been achieved. It will cycle on and off throughout the cooking time.
- You should not place food inside the cavity, until the correct cooking temperature has been achieved.

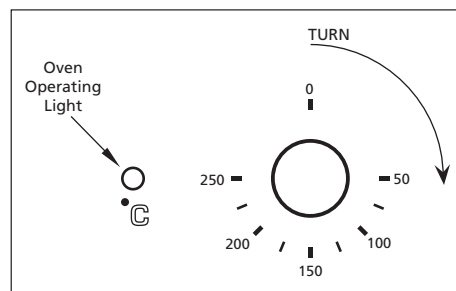

COOKING GUIDELINES

- Please refer to the information given on food packaging for guidance on cooking temperatures and times. Once familiar with the performance of your appliance, temperatures and times can be varied to suit personal preference.
- If you are using the fan oven function, follow the information given on the food packaging for this particular mode of cooking.
- Ensure that frozen foods are thoroughly thawed before cooking, unless the instructions on the food packaging advise that you can "cook from frozen".
- You should pre-heat the oven and not place food inside of it until the oven operating light has switched off. You can choose not to pre-heat when using the fan oven mode; however you should extend the cooking time given on the food packaging by approximately ten minutes.
- Before cooking, ensure accessories that are not required are removed from the oven.
- Place cooking trays in the centre of the oven and leave gaps between the trays to allow air to circulate.
- Try to open the door as little as possible to view the dishes.
- The oven light will remain lit during cooking.

OPERATING INSTRUCTIONS

WARNINGS

- Keep the oven door closed when using any of the grill functions.
- Do not use aluminium foil to cover the grill pan or heat items wrapped in aluminium foil under the grill. The high reflectivity of the foil could potentially damage the grill element.
- You should also never line the base of your oven with aluminium foil.
- During cooking, never place pans or cookware directly onto the bottom of your oven. They should always be placed on the shelves provided.
- The grill heating element and other internal components of the oven become extremely hot during operation; avoid contact with it when handling the food.
- Important: Exercise caution when opening the door so as to avoid contact with hot parts of the oven and steam.
- The drip tray handle should only be used to reposition the drip tray and NOT for removing it from the oven cavity. When removing the drip tray, you should ALWAYS use an oven glove.
- The drip tray handle should not be left in position when the appliance is switched on.
- Do not use a steam cleaner.
- WARNING: Accessible parts may become hot during use. Young children should stay well away from appliance when in use.
- Do not use harsh abrasive cleaners or metal scrapers to clean the oven door glass as this can scratch the surface, which may result in the oven glass shattering.

ACCESSORIES

Your oven is supplied with the following oven accessories:

A - Oven Rack

B - Drip Tray

1-4 - Rack Support

- The numbers 1 - 4, indicate the different shelf positions that you can utilise within the oven.

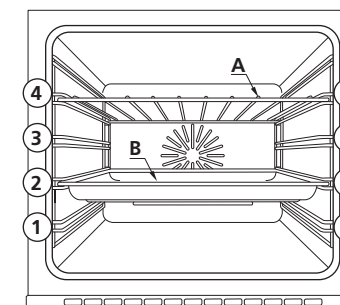

SETTING AND USING THE OVEN PROGRAMMER/TIMER

SETTING THE END COOK FUNCTION

This function is similar to the duration function, however instead of selecting a period of time that you wish the oven to switch off, you select the time of day that you wish the oven to switch off at.

- Use the thermostat control knob (3) to set the temperature that you require. The manual operation symbol (14) will appear on the display.
- Use the oven function selector knob (1) to select the mode of cooking that you require.
- Press the "end cook" button (8) and the display will show a value of 00:00. Set the time of day that you wish the oven to stop cooking at by using the "minus" and "plus" buttons. The timer will calculate how long the cooking time will be, based on the time of day that you have selected and show it on the display.
- Once the display shows the time of day that you want the oven to stop cooking at, release the "minus" and "plus" buttons. The countdown will start immediately and the word AUTO symbol will appear on the timer display.
- When the time is set, it can be modified by pressing the "minus" and "plus" buttons.
- When the time of day reaches the end of cooking time that you set, the oven will switch off and an alarm will sound. The word AUTO will flash and the heating symbol will disappear. The alarm can be silenced by pressing the "end cook" button.
- You will need to reset the oven to manual operation mode, once the end cook function has been used. To do this - press the "manual operation" button, the word AUTO will disappear from the display and the manual operation symbol will appear instead.
- **IMPORTANT:** If you do not turn the thermostat control knob and oven function selector knob to 0, then the appliance will continue to operate as soon as you press the "manual operation" button.

SETTING THE START AND END TIME FUNCTION

This function will allow you to set a time in the future, allowing the oven to switch on and off at a preset time.

- Use the thermostat control knob (3) to set the temperature that you require. The manual operation symbol (14) will appear on the display.
- Use the oven function selector knob (1) to select the mode of cooking that you require.
- Press the "duration" button (7) and the display will show a value of 00:00. Set the period of time that you wish to cook for, by using the "minus" (10) and "plus" (11) buttons. The word AUTO will appear on the timer display.
- Immediately press the "end cook" button (8) and the timer display will show the value 00:00. Set the time of day that you want the oven to switch off at, using the "minus" and "plus" buttons.
- The oven will calculate what time it needs to switch on at, so that your food will cook for the length of time that you selected. It will automatically switch itself on, once it reaches the time of day that you set previously.
- When the time of day reaches the end of the cooking time that you set, the oven will switch off and an alarm will sound. The word AUTO will flash and the heating symbol will disappear. The alarm can be silenced by pressing the "end cook" or "duration" button.
- You will need to reset the oven to manual operation mode, once the start and end time function has been used. To do this - press the "manual operation" button, the word AUTO will disappear from the display and the manual operation symbol will appear instead.
- **IMPORTANT:** If you do not turn the thermostat control knob and oven function selector knob to 0, then the appliance will continue to operate as soon as you press the "manual operation" button.

INSTALLATION

- The installation must be carried out by a suitably qualified person, in accordance with the current version of the following.
- Before connecting the appliance, make sure that the supply voltage marked on the Rating Label corresponds with your power supply voltage.

WARNING: THIS APPLIANCE MUST BE EARTHED.

This appliance should be wired into a 13 A double pole switched fused spur outlet, having 3 mm contact separation and placed in an easily accessible position adjacent to the appliance. The spur outlet must still be accessible even when your oven is located in its housing to enable the appliance to be disconnected from the mains supply.

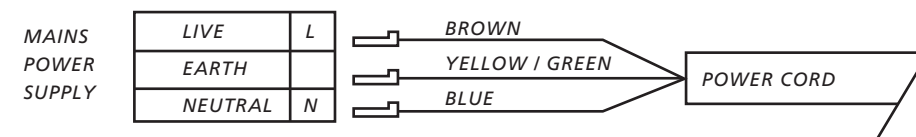

- To connect the oven power cord, loosen and remove the cover on the terminal block, in order to gain access to the contacts inside. Make the connection, securing the cord in place with the cable clamp provided and then immediately close the terminal block cover again.
- If you have to change the oven power cord, the earthing (yellow/green) conductor must always be 10 mm longer than the line conductors.
- Care must be taken to ensure that the temperature of the power supply cable does not exceed 50°C.
- If the power supply cable is damaged, contact the manufacturer or authorised service centre to have it replaced or repaired.

INSTALLING THE OVEN INTO THE KITCHEN CABINET

POSITIONING THE APPLIANCE

- Ensure that the aperture that you will be fitting the oven into is of the size given in the below diagram.
- The oven must be fitted into oven housing with the ventilation cut-outs shown in the "Ventilation requirements" section on the next page.
- Ensure that the rear panel of the furniture housing unit has been removed.

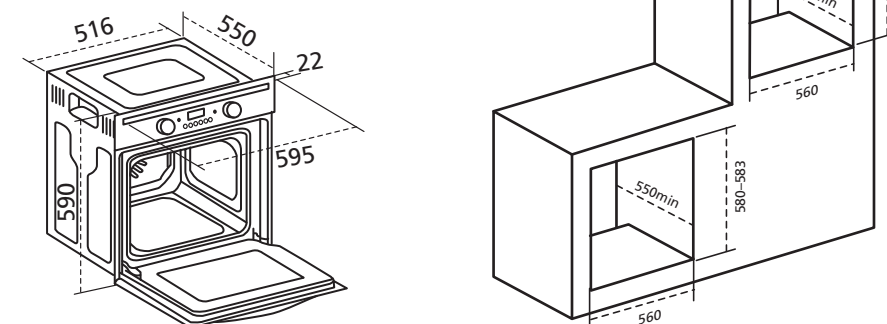

CONTROL PANEL

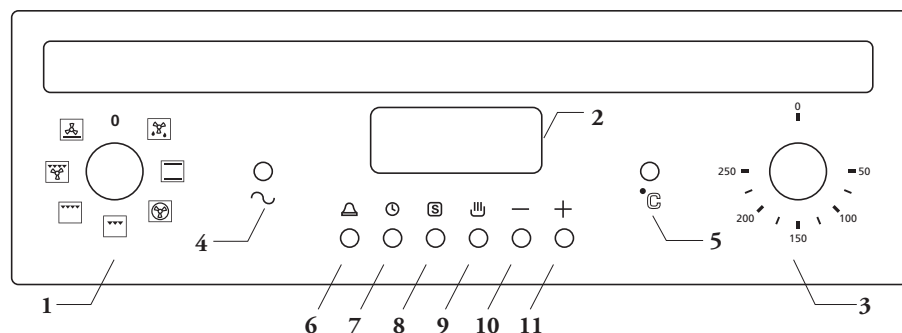

1. Oven function selector knob
2. Timer knob
3. Thermostat control knob
4. Power indicator light
5. Oven operating light
6. Timer "minute minder" button
7. Timer "duration" button
8. Timer "end cook" button
9. Timer "manual operation" button
10. Timer "minus" button
11. Timer "plus" button

OVEN PROGRAMMER/TIMER DISPL

12. "Auto" function symbol
13. "Minute minder" symbol
14. "Manual operation" symbol

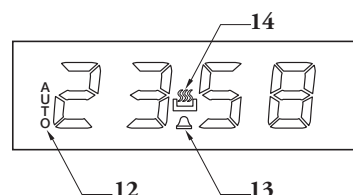

TROUBLESHOOTING

The oven does not power on.	<ul style="list-style-type: none"> Ensure that the oven is in operation mode. Ensure that you have selected a cooking function and a cooking temperature.
There appears to be no power to the oven and grill.	<ul style="list-style-type: none"> Ensure that the appliance has been connected to the power supply correctly. Ensure that the power supply fuses are in working order. Ensure that the operating instructions for setting the time of day and putting the appliance into manual operation mode have been followed.
The grill function works but the main oven does not.	<ul style="list-style-type: none"> Ensure that you have selected the correct cooking function.
The grill and top oven element is not working, or cuts out for long periods of time during every use.	<ul style="list-style-type: none"> Allow the oven to cool for approximately 2 hours. Once cool, check whether the appliance is again working properly.
Food is not cooking properly	<ul style="list-style-type: none"> Ensure that you are selecting the correct temperature and the correct cooking function for the food that you are cooking. It may be appropriate to adjust your cooking temperature by plus or minus 10°C, to achieve the best cooking results.
Food is not cooking evenly	<ul style="list-style-type: none"> Check that the oven has been installed correctly and is level. Check that the correct temperatures and shelf positions are being used.
The oven light is not working	<ul style="list-style-type: none"> Refer to page 11 and follow the "Replacing the oven bulb" section.
There is condensation inside the oven	<ul style="list-style-type: none"> Steam and condensation is a natural by-product of cooking any food with high water content, such as frozen food, chicken etc. Condensation may occur in the oven cavity and forming between the oven door glasses. This is not necessarily a sign that the oven is not working correctly. Do not leave food in the oven to cool after it has been cooked, even when the oven has been switched off. Use a covered container during cooking to reduce the amount of condensation that forms.

IMPORTANT: If your appliance appears to have malfunctioned, please contact the distributor.

SETTING AND USING THE OVEN PROGRAMMER/TIMER

SELECTING MANUAL OPERATION MODE

- After your appliance is connected to the power supply for the first time, the numbers on the timer display will flash. Before you can select a cooking function or set a temperature, you must set the appliance into "manual operation" mode.
- To select manual operation mode, press the "manual operation" button (9) on the control panel.

SETTING THE TIME OF DAY

- After manually setting your, proceed to set the time of the day.
- After pressing the "manual operation" button (9), use the "minus" button (10) and "plus" button (11) to adjust the time that appears on the display. After setting the correct time, release the "minus" and "plus" buttons. After a few seconds the set time will appear on the display and you will be able to use your oven.

THE OVEN TIMER

- Only the minute minder can be used with the defrost oven function. Any of the other timer settings will not work with the defrost oven function.

NOTE: This User Instruction Manual contains important information, including safety & installation points, which will enable you to get the most out of your appliance. Please keep it in a safe place so that it is easily available for future reference; for you or any person not familiar with the operation of the appliance.

IMPORTANT SAFETY INFORMATION

Your safety should always remain the topmost priority. Please ensure that you read this User Manual before attempting to install or use the appliance. If you are unsure of any of the information contained in this booklet, please contact our Technical Department.

GENERAL INFORMATION

- This appliance is designed for domestic household use and can be incorporated into a standard kitchen cabinet or housing unit.
- **IMPORTANT:** The adjacent furniture or housing and all materials used in the installation must be able to withstand a minimum temperature of 85°C above the ambient temperature of the room it is located in, whilst in use.
- Certain types of vinyl or laminate kitchen furniture are particularly prone to heat damage or discolouration at temperatures below the guidelines given above.
- We will not be liable for any damage caused by the appliance if it is installed in contravention of the temperature limit, or by placing adjacent cabinet materials closer than 4mm to the appliance.
- The use of this appliance for any other purpose or in any other environment without the express agreement of our company will invalidate any warranty or liability claim.
- Your new appliance is guaranteed against electrical or mechanical defects, subject to certain exclusions that are noted in Conditions Of Guarantee. The foregoing does not affect your statutory rights.
- It is recommended that repairs be carried out by our Service Engineers or their authorized service agents only.

WARNING AND SAFETY INSTRUCTIONS

This appliance complies with all current European safety legislation.

IMPORTANT: The appliance surfaces will become hot during use and retain heat after operation.

GENERAL SAFETY

- This appliance is not intended for use by persons (including children) with reduced physical sensory or mental capabilities, or lack of experience and knowledge, unless they have been given supervision or instruction concerning use of the appliance by a person responsible for their safety.
- Do not place heavy objects on the oven door or lean on the oven door when it is open, as this can cause damage to the oven door hinges.
- Do not leave heated oil or fat unattended, as this is a fire risk.
- Do not place pans or baking trays directly on the base of the oven cavity, or line it with aluminium foil.
- Do not allow electrical fittings or cables to come into contact with areas on the appliance that are prone to heat.
- Do not use the appliance to heat the room or near dry clothing as it may be a fire hazard
- Do not install the appliance next to curtains or soft furnishings.
- Do not attempt to lift or move cooking appliances by using the oven door or handle, as this may cause damage to the appliance or result in injury to the person lifting the appliance.

MAIN COOKING FUNCTIONS GUIDELINE



TOP HEATING ELEMENT

Food	Weight	Preheat time	Tray position	Temperature setting	Finish time
Steak	0.8 kg	10 min	3rd layer	250°C	20-25 min
Chicken	1.2 kg	10 min	3rd layer	250°C	40-45 min
Sausage	0.6 kg	10 min	4th layer	250°C	15-20 min
Hamburger	0.6 kg	10 min	4th layer	250°C	15-20 min
Corn	1.2 kg	10 min	3rd layer	250°C	20-25 min
Vegetable	0.5 kg	10 min	4th layer	250°C	15-20 min



BOTTOM HEATING ELEMENT + FAN

Food	Weight	Preheat time	Tray position	Temperature setting	Finish time
Bread	0.5 kg	10 min	1st layer	200°C	10-15 min
Pizza	0.7 kg	15 min	2nd layer	200°C	40-45 min
Yeast Cake	1.5 kg	15 min	1st layer	180°C	35-40 min
Biscuit	0.7 kg	15 min	2nd layer	180°C	20-25 min
Fruit Salad Pie	1.2 kg	10 min	3rd layer	250°C	20-25 min

* The above cooking suggestions serve as a guideline only

