

 **Mórgan[®]**

 **Mórgan[®]**

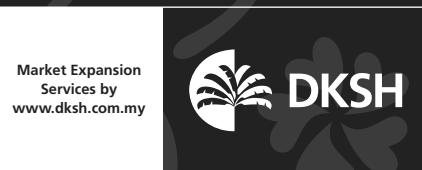

E-mail: electrical.appliance@dksh.com
www.morgan.my

 facebook.com/morganappliances

USER MANUAL

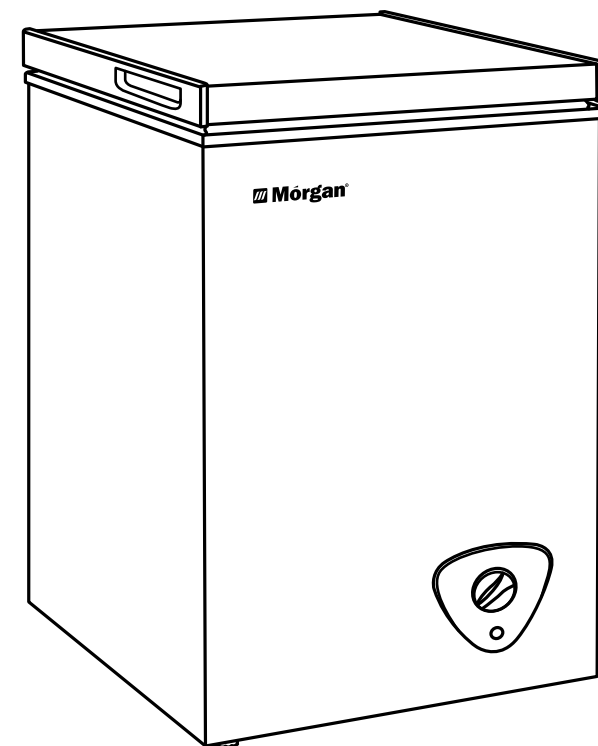

Chest Freezer

MCF-ADVENT88L

FOOD STORAGE & QUICK-FREEZING

1. Do not put large amount of food into the unit at all once.
2. Allow warm food to cool down to room temperature before placing into the unit.
3. Ensure ample space around food.
4. Section food according to food category and store in the same section.
5. Do not place glass bottles and cans with higher freezing points than the compartment temperature to avoid breakage and injuries.
6. Do not put flammable, explosive, or corrosive items or volatile organic solvents into the freezer to prevent accidents and to protect the freezer cabinet from corrosion.

DEFROSTING

1. Defrost if frost on the interior walls exceed 5mm.
2. Power off the unit and open the doors for natural defrosting.
3. Dry and clean the unit with the soft cloth after defrosting.
4. Never use sharp metal tools to scrape off frost as you could damage the appliance.
5. Do not use a mechanical device or any artificial means to speed up the thawing process other than those recommended by the manufacturer.

CARE & CLEANING

1. Unplug power cord from the power supply and remove all food contents inside the freezer.
2. Wash the interior with a damp cloth.
3. Ensure the door gasket (seal) is clean to keep the unit running efficiently. Rubbing some talcum powder on the door gasket can prolong its operating life.
4. Clean the freezer's exterior with mild detergent and warm water.
5. Dry the interior and exterior with a soft cloth.
6. The condenser coils should be vacuumed when they are dusty or dirty.
7. It is recommended to clean the unit each time after defrosting to keep it odor free and running efficiently.

IMPORTANT SAFEGUARDS

When using electric appliances, basic safety precautions should always be followed including the following:

1. Read all instructions before using the freezer.
2. A fitting one phase alternating power must be supplied to the unit. It is recommended to use a power regulator if voltage fluctuation is high to avoid compressor burnout.
3. Improper use of the grounded power plug can result in the risk of electrical shock.
4. If the power cord is damaged, have it replaced by an authorized service center or a similarly qualified technician.
5. It is advisable to use a single-phase power socket with corresponding fuse. Do not use a multi-extension cord as this may pose an electrical or fire electrical hazard.
6. To protect against electric shock, do not immerse power cord, power plug, or any parts of the freezer in water or other liquids.
7. Do not operate the unit with a damaged power cord or power plug or after the appliance malfunctions or has been damaged in any manner. In such a situation, it is recommended to return the appliance to your nearest Authorized Service Center for examination, repair, or adjustment.
8. It is recommended to wait for 5 minutes before restarting the unit if it has been unplugged, powered off, or experiences a power outage.
9. Never install the unit near flammable or heat sources, or where it may be exposed to acid or corrosive gas which may cause the risk of explosion or fire.
10. Never splash water on the exterior or interior of the unit to avoid the risk of electrical shock or short circuit.
11. Do not store flammable gas and corrosive liquids in the unit because they may explode.
12. Do not store carbonated, fizzy drinks, medicine or medical products in the unit as it creates pressure on the container, which may cause it to explode, resulting in damage to the appliance.
13. **WARNING:** Handling frozen items with bare hands may cause frostbite. Always wear oven mitts or gloves.
14. This appliance is not intended for use by persons (including children) with reduced physical, sensory or mental capabilities, or lack of experience and knowledge, unless they have been given supervision or instruction concerning use of the appliance by a person responsible for their safety.
15. Children should be supervised to ensure that they do not play with the appliance.
16. Do not break the loop of the cooling system.
17. Do not keep any electrical appliances in the food closet of the freezer.
18. Do not use mechanical devices or other means to accelerate the defrosting process other than those recommended by the manufacturer.

IMPORTANT SAFEGUARDS

19. Damaged lamp or any electrical work required for the servicing of the unit should only be carried out by a qualified technician or competent person.
20. This appliance is intended for keeping foodstuff and/or beverages in a normal household and similar applications such as:
 - staff kitchen areas in shops, offices and other working environments;
 - farm houses and by clients in hotels, motels and other residential type environments;
 - bed and breakfast type environments;
 - catering and similar non-retail applications.

PORTAGE AND PLACEMENT

1. Keep upright as possible during handling, tilt 45°, never upside down or horizontally and do not roll unit over uneven surface during the transportation.
2. Place the appliance away from the direct sunlight and heat sources from stove, heater, radiator etc., as direct sunlight may damage the acrylic coating while heat sources will increase power consumption.
3. Keep the appliance stable by adjusting the four castors when necessary.
4. All packaging material should be removed. Do not use bottom foam as vibration-proof material.
5. It is recommended to keep at least 100mm of ventilation space away from the back and sides of the unit for proper air circulation to cool the compressor.

PREPARATION BEFORE USE

1. Remove shipping packaging, tape, etc. and leave the lid open for ventilation for a while.
2. This freezer should be properly grounded for your safety.
3. Connect the unit's power cord to the power supply with the rated frequency and rated voltage indicated on the rating label.
4. Use the input power regulator with 5 times alternating power if the voltage fluctuates than usual.
5. Secure the power cord behind the freezer. Do not leave it exposed or dangling to prevent accidental tripping over which may result in injuries.
6. Use the specified power socket and suitable fuse.
7. Always hold on the power plug and never pull the power cord.
8. Never splash water on the unit directly to avoid the risk of electric shock or short circuit.
9. **IMPORTANT:** Before connecting the unit to the power supply, allow it stand upright for about 6-12 hours to reduce the possibility of a cooling system malfunction during transportation.
10. Clean the interior surface with lukewarm water using a soft cloth.
11. In the event of a power outage, turn the power on 5 minutes later to protect the system and compressor.
12. Do not use an extension cord with this appliance. If the power cord is too short, have a qualified electrician or service technician to rectify it. The use of an extension cord can negatively affect the performance of the unit.
13. Turn on the power and turn the temperature control knob to 3~4 position.
14. Ensure that the indicator light, compressor and ventilating fan are operating after half an hour.

TEMPERATURE CONTROL AND ADJUSTMENT

1. The inner temperature can be adjusted through the temperature control knob.
2. The higher the number, the lower temperature.
3. Normal temperature is positioned between 3 and 4.
4. "1-2" position refers to refrigerate and the inner storage temperature of about 10°C-0°C.
5. To quickly freeze food, turn the knob to "6-7" clockwise. The compressor will operate continuously.
6. Turn the knob back to its original position after quick freezing. Do not turn the temperature control knob clockwise from "7" to "1".

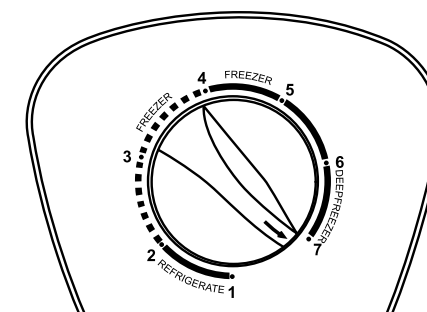

Thank you for purchasing a quality MORGAN appliance. We trust that you will have a pleasant experience with your new product. To guarantee safety and best efficiency, please read this

PARTS IDENTIFICATION

1. Handle
2. Basket
3. Cabinet
4. Compressor room cover
5. Temperature control panel
6. Castor

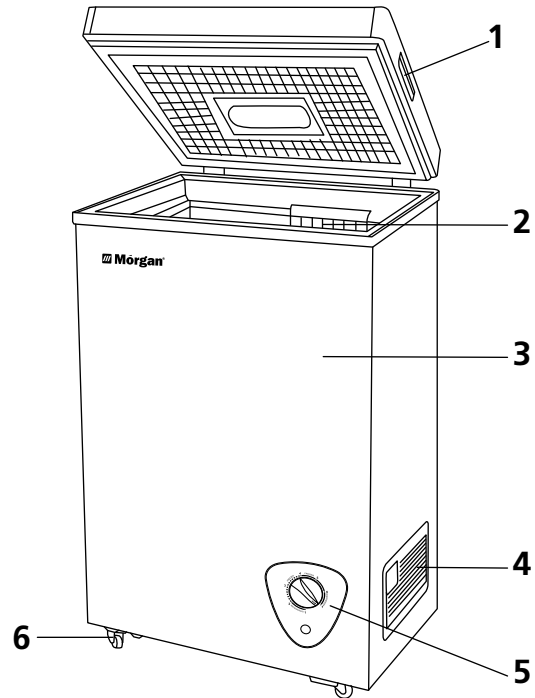

PARTS IDENTIFICATION

MODEL NO.	MCF-ADVENT88L
RATED VOLTAGE	220-240V~
FREQUENCY	50Hz
RATED CURRENT	0.75A
CAPACITY	74L

TROUBLESHOOTING

- **CAUTION!** Before troubleshooting, disconnect the power supply.
- Only a qualified electrician or competent person must perform troubleshooting that is not listed in this user manual.

PROBLEM	POSSIBLE SOLUTIONS
The unit is not working	<ul style="list-style-type: none"> • Not plugged into power supply. • Circuit breaker tripped or blown fuse. • Temperature control is set too warm.
Unit is not cold enough	<ul style="list-style-type: none"> • Ensure that the temperature is set correctly. • Try to reduce the temperature in the room where the appliance is placed. • The door is opened too often. • The door is not closed completely. • The door gasket is not properly sealed. • The unit does not have the correct clearance.
Compressor turns on & off continuously	<ul style="list-style-type: none"> • The room temperature is warmer than normal. • The unit has too many contents. • The door is opened too often. • The door is not closed completely. • The temperature control is not set correctly. • The door gasket is not properly sealed. • The unit does not have the correct clearance.
Vibrations felt during operation	<ul style="list-style-type: none"> • Ensure that the unit is placed on a level and stable surface. • Refrigerant flow may emit rattling noises. This is normal. • As each cycle ends, the flow of refrigerant may emit gurgling sounds. • Contraction of the unit's interior walls may emit popping and crackling noises. • The unit is not placed on a level and stable surface.
Door does not close properly	<ul style="list-style-type: none"> • The unit is not placed on a level or stable surface. • The door gasket is dirty. • The shelves are out of position.
Dew on surface of the unit	<ul style="list-style-type: none"> • This is normal as the temperature on the compressor surface can reach about 70°C - 90°C during its operation. Wipe with dry cloth.